



**FA Cyclone**

**Maintenance Manual**

## Contents

1. PRODUCT DESCRIPTION .....	2
1.1. How it works .....	3
1.2. Accessories.....	4
1.2.1. Supporting legs .....	4
1.2.2. Heavy dustbin .....	4
1.2.3. Light dustbin .....	5
1.2.4. Expansion chamber.....	5
1.3. Overall dimensions.....	6
1.4. Technical datasheet .....	8
2. INTALLATION .....	11
2.1. Cyclone installation .....	11
2.2. Installing a cyclone with legs.....	12
2.3. Installing the dustbin .....	14
2.4. Removing the dustbin .....	16
2.5. Installing the expansion chamber .....	17
3. MAINTENANCE & TROUBLESHOOTING.....	19
3.1. Removing the dustbin transition .....	19
3.2. Replacing the leg support .....	19
3.3. Replacing a cyclone's part.....	20
4. DISMANTLING & RECYCLING.....	21
5. SPARE PARTS .....	22

## FA Cyclone . Maintenance Manual

### 1. PRODUCT DESCRIPTION

The cyclone FA is a high efficiency separator which guarantees an efficient separation of the fine as well as the bigger particles. It can be used for several industrial applications, such as heavy molding, grinding, planing, cabinet workshops, dust transfer systems or material separation.

It is an economical solution to a wide range of dust collection problems.

Manufactured in 2.0 mm or 3.0 mm sheet metal, powder coated RAL 5010 with a rustproof protection; it is easily mounted in or outdoors.

Legs, dustbin and expansion chamber are optional and are available as separate parts.

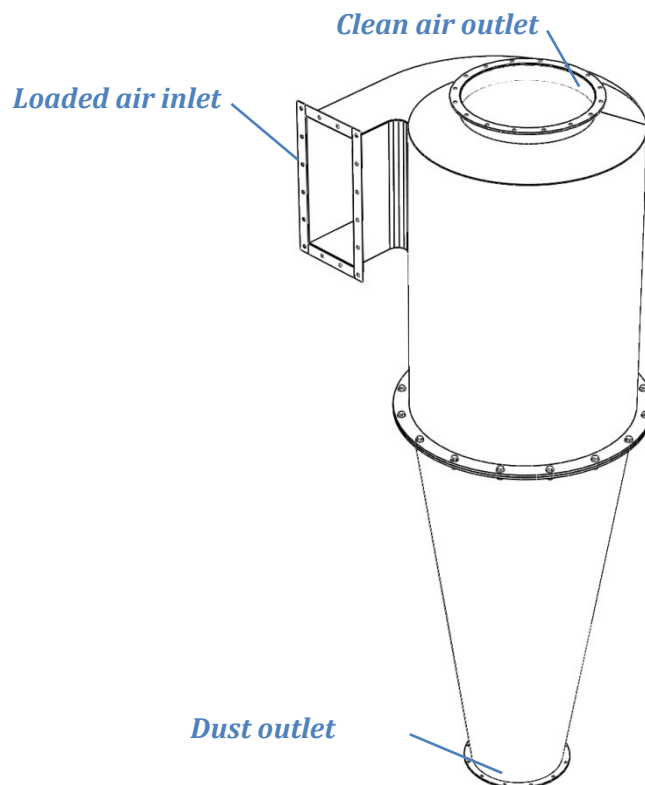

## 1.1. How it works

- During normal operation, dust laden air enters the FA cyclone unit through the loaded air inlet.
- The air and the material are diverted into a spiral motion around the inside perimeter. The centrifugal force applied by the sidewall allows the heavier material to fall out the dust outlet into the dust bin, or through a rotary valve.
- Clean air is carried through the inner cylinder and discharges into the atmosphere or secondary filters.

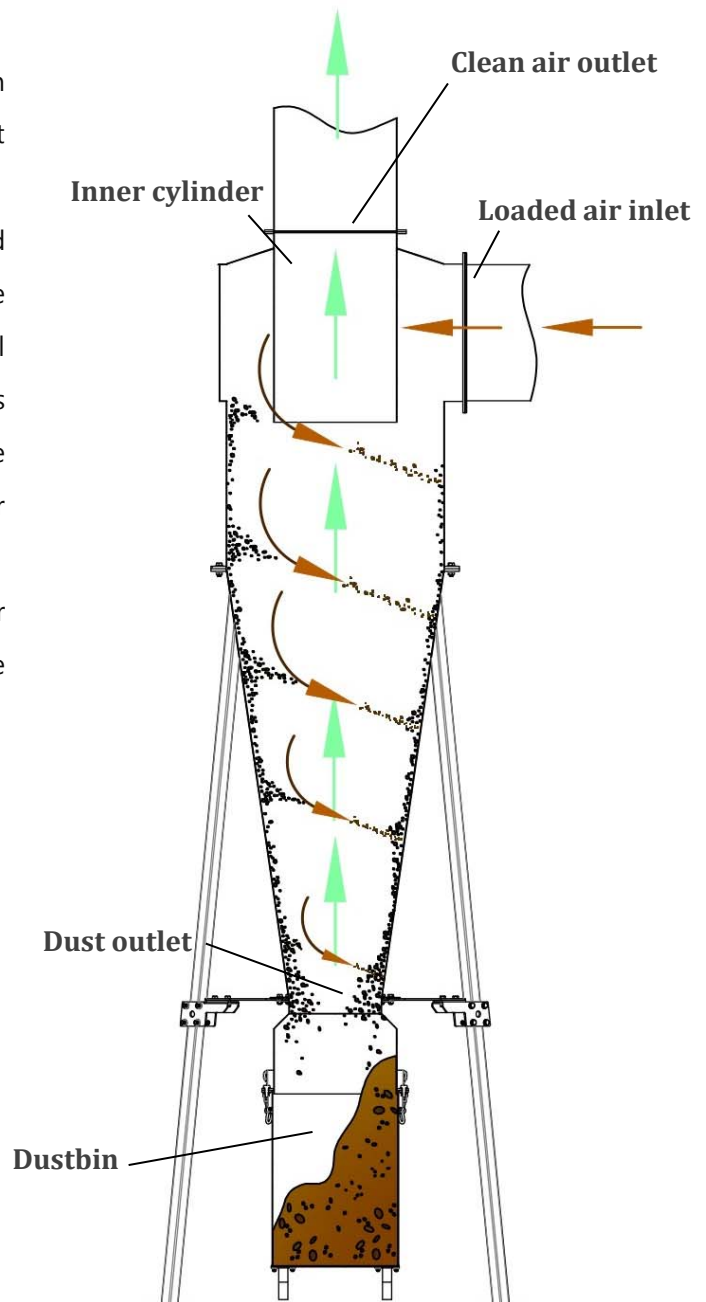

## 1.2. Accessories

### 1.2.1. Supporting legs

Square profiled legs, welded to 5mm or 8mm sheet metal holders. Powder coated RAL 5010.

\* For overall dimensions, please see attached tables in **Chapter 1.3**.

\*\* For technical data, please see attached tables in **Chapter 1.4**.

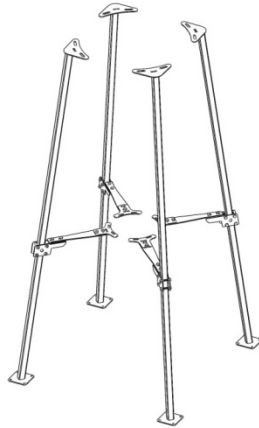

### 1.2.2. Heavy dustbin

The heavy dustbin collects the dust or other particles from the cyclone that is subtracted from the air. It can be easily removed by opening the locks and removing the two bolts. Once removed, the dustbin can be rolled out on its integrated wheels and the contents can be emptied. The dustbin is made out of 2 mm ST37 sheet metal, powder coated in RAL 5010.

**CAUTION!** The waste material must be disposed of in compliance with the national laws and/or local legislations in force.

\* For overall dimensions, please see attached tables in **Chapter 1.3**.

\*\* For technical data, please see attached tables in **Chapter 1.4**.

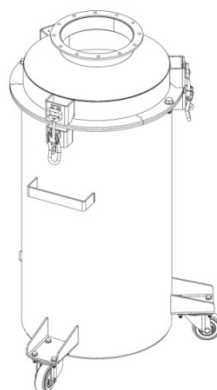

### 1.2.3. Light dustbin

The light dustbin serves the same purpose as the heavy execution. It can be easily removed by opening the lock-ring. Once removed, the dustbin can be carried away and the contents can be emptied. The dustbin is made out of 1 mm galvanized sheet metal.

**CAUTION!** The waste material must be disposed of in compliance with the national laws and/or local legislations in force.

\* For overall dimensions, please see attached tables in **Chapter 1.3**.

\*\* For technical data, please see attached tables in **Chapter 1.4**.



### 1.2.4. Expansion chamber

The expansion chamber allows to optimize the FA cyclone's efficiency and gives a better air/ dust separation. The expansion chamber is made of ST37 sheet metal, powder coated RAL5010.

\* For overall dimensions, please see attached tables in **Chapter 1.3**.

\*\* For technical data, please see attached tables in **Chapter 1.4**.

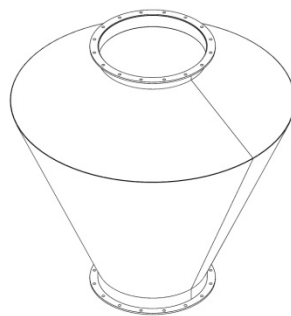

### 1.3. Overall dimensions

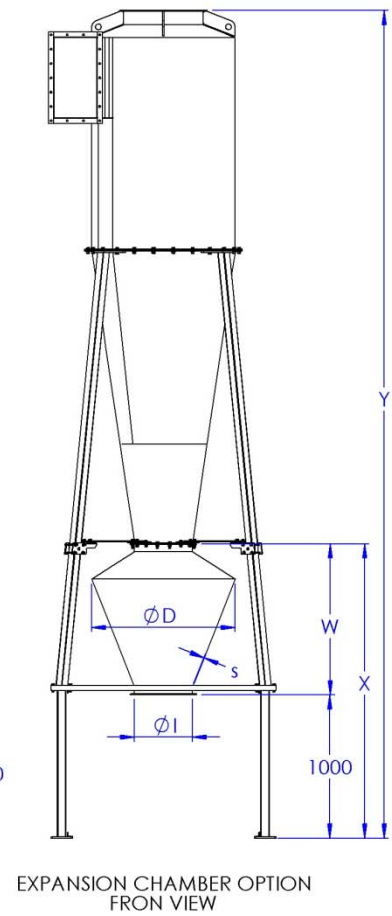
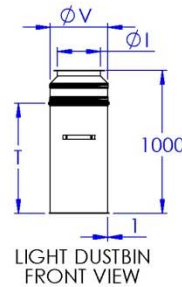
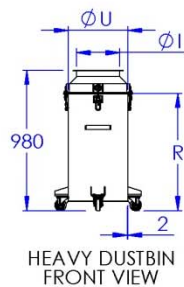
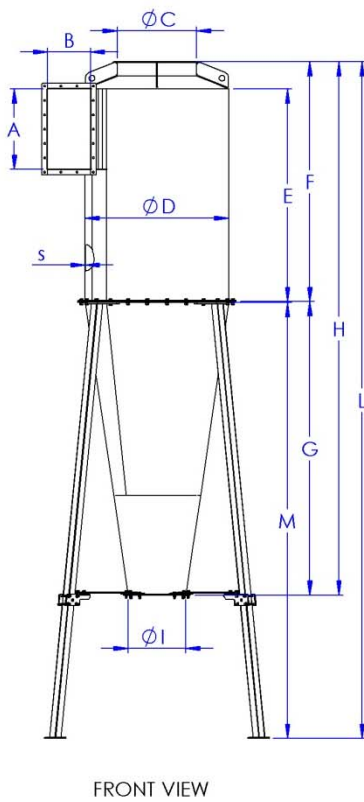
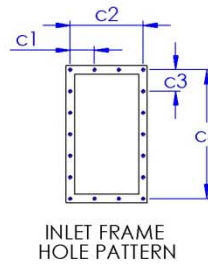
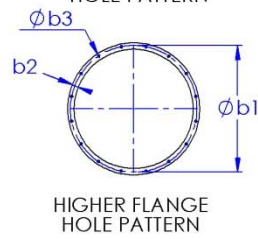
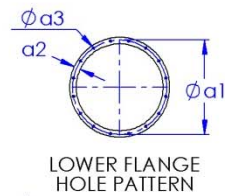
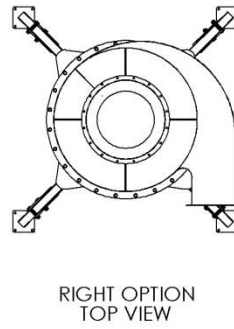
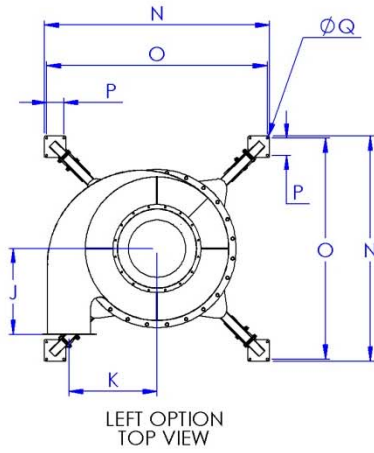

— Drawing Lines  
— Dimensions

**Cyclone**

Type	A mm	B mm	C mm	D mm	E mm	F mm	G mm	H mm	I mm	J mm	K mm	s mm
FA-020	230	100	∅ 225	∅ 399	570	645	820	1465	∅ 160	240	234	2
FA-035	285	125	∅ 250	∅ 499	710	770	1020	1790	∅ 200	300	290	2
FA-050	350	160	∅ 250	∅ 499	710	770	1020	1790	∅ 200	300	308	2
FA-065	445	200	∅ 400	∅ 709	998	1104	1414	2518	∅ 300	420	419	2
FA-100	560	300	∅ 550	∅ 1000	1490	1675	2050	3725	∅ 400	600	615	2
FA-130	750	400	∅ 698	∅ 1248	2000	2269	2820	5089	∅ 448	700	782	3
FA-160	1100	500	∅ 798	∅ 1598	2000	2270	3150	5420	∅ 548	900	1050	3
FA-180	1500	500	∅ 998	∅ 1798	2500	2800	3450	6250	∅ 628	950	1150	3

**Legs, dustbin, expansion chamber**

Type	L mm	M mm	N mm	O mm	P mm	Q mm	R mm	T mm	U mm	V mm	W mm	X mm	Y mm
FA-020	2465	1816	670	840	100	∅ 14	980	720	∅ 410	∅ 400	454	1454	2919
FA-035	2790	2012	981	951	100	∅ 14	980	720	∅ 410	∅ 400	554	1554	3344
FA-050	2790	2012	981	951	100	∅ 14	980	720	∅ 410	∅ 400	554	1554	3344
FA-065	3518	2414	1214	1184	100	∅ 14	980	720	∅ 410	∅ 400	764	1764	4282
FA-100	4725	3042	1573	1543	120	∅ 14	980	720	∅ 410	∅ 400	1054	2054	5779
FA-130	6089	3810	1955	1915	140	∅ 14	980	720	∅ 410	∅ 400	1304	2304	7393
FA-160	6420	4140	2258	2218	140	∅ 14	980	720	∅ 410	∅ 400	1654	2654	8074
FA-180	7250	4440	2501	2461	170	∅ 14	980	720	∅ 410	∅ 400	1854	2854	9104

**Flanges**

Type	a1 mm	a2 mm	a3 mm	b1 mm	b2 mm	b3 mm	c1 mm	c2 mm	c3 mm	c4 mm	c5 mm
FA-020	∅ 215	25	∅ 9 (x8)	∅ 280	25	∅ 9 (x12)	70	140 (2x 70)	90	270 (3x 90)	∅ 13
FA-035	∅ 255	25	∅ 9 (x12)	∅ 305	25	∅ 9 (x12)	82.5	165 (2x 82.5)	108	325 (3x 108)	∅ 13
FA-050	∅ 255	25	∅ 9 (x12)	∅ 305	25	∅ 9 (x12)	100	200 (2x 100)	97.5	390 (4x 97.5)	∅ 13
FA-065	∅ 336	25	∅ 9 (x12)	∅ 439	30	∅ 11 (x16)	80	240 (3x 80)	97	485 (5x 97)	∅ 13
FA-100	∅ 465	30	∅ 11 (x16)	∅ 615	30	∅ 11 (x16)	113	340 (3x 113)	100	600 (6x 100)	∅ 13
FA-130	∅ 515	30	∅ 11 (x16)	∅ 785	40	∅ 11 (x24)	110	440 (4x 110)	99	790 (8x 99)	∅ 13
FA-160	∅ 615	30	∅ 11 (x16)	∅ 885	40	∅ 11 (x24)	108	540 (5x 108)	104	1140 (11x 104)	∅ 13
FA-180	∅ 695	30	∅ 11 (x24)	∅ 1085	40	∅ 11 (x24)	108	540 (5x 108)	103	1540 (15x 103)	∅ 13



## 1.4. Technical datasheet

### FA Cyclone

Type	Total volume m <sup>3</sup>	Total mass kg	Higher cone mass kg	Lower cone mass kg
FA-020	0,13	40	25	15
FA-035	0,25	57	35	23
FA-050	0,25	58	36	23
FA-065	0,7	113	70	43
FA-100	2,08	226	143	83
FA-130	4,3	538	339	199
FA-160	7,3	754	475	278
FA-180	10,95	1025	682	342

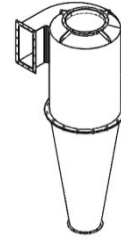

### FA Cyclone with legs

Type	Total volume m <sup>3</sup>	Total mass kg	Legs mass kg
FA-020	0,13	78	37
FA-035	0,25	99	41
FA-050	0,25	100	41
FA-065	0,7	162	49
FA-100	2,08	326	100
FA-130	4,3	692	154
FA-160	7,3	922	168
FA-180	10,95	1301	276

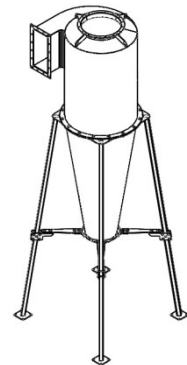

### FA Cyclone with legs and heavy dustbin

Type	Total mass kg	Dustbin mass (Heavy) kg	Dustbin volume m <sup>3</sup>
FA-020	111	34	0,1
FA-035	132	34	0,1
FA-050	133	34	0,1
FA-065	195	34	0,1
FA-100	360	34	0,1
FA-130	747	34	0,1
FA-160	977	34	0,1
FA-180	1356	34	0,1

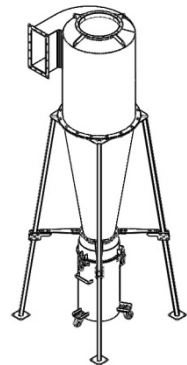

**FA Cyclone with legs and light dustbin**

Type	Total mass kg	Dustbin mass (light) kg	Dustbin volume m <sup>3</sup>
FA-020	91	13	0,1
FA-035	112	13	0,1
FA-050	113	13	0,1
FA-065	175	13	0,1
FA-100	339	13	0,1
FA-130	705	13	0,1
FA-160	935	13	0,1
FA-180	1315	13	0,1

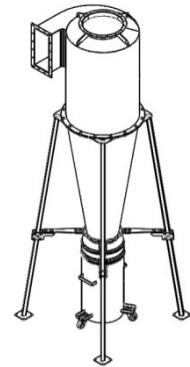
**FA Cyclone with legs and expansion chamber**

Type	Total mass kg	Expansion chamber mass kg	Expansion chamber volume m <sup>3</sup>
FA-020	101	8	0,02
FA-035	128	12	0,05
FA-050	129	12	0,05
FA-065	210	24	0,15
FA-100	421	46	0,4
FA-130	875	101	0,75
FA-160	1231	164	1,54
FA-180	1724	206	2,22

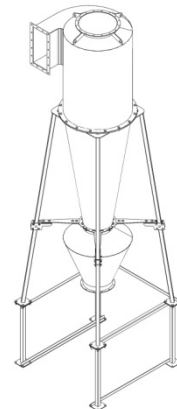

*Pressure loss in FA cyclones*

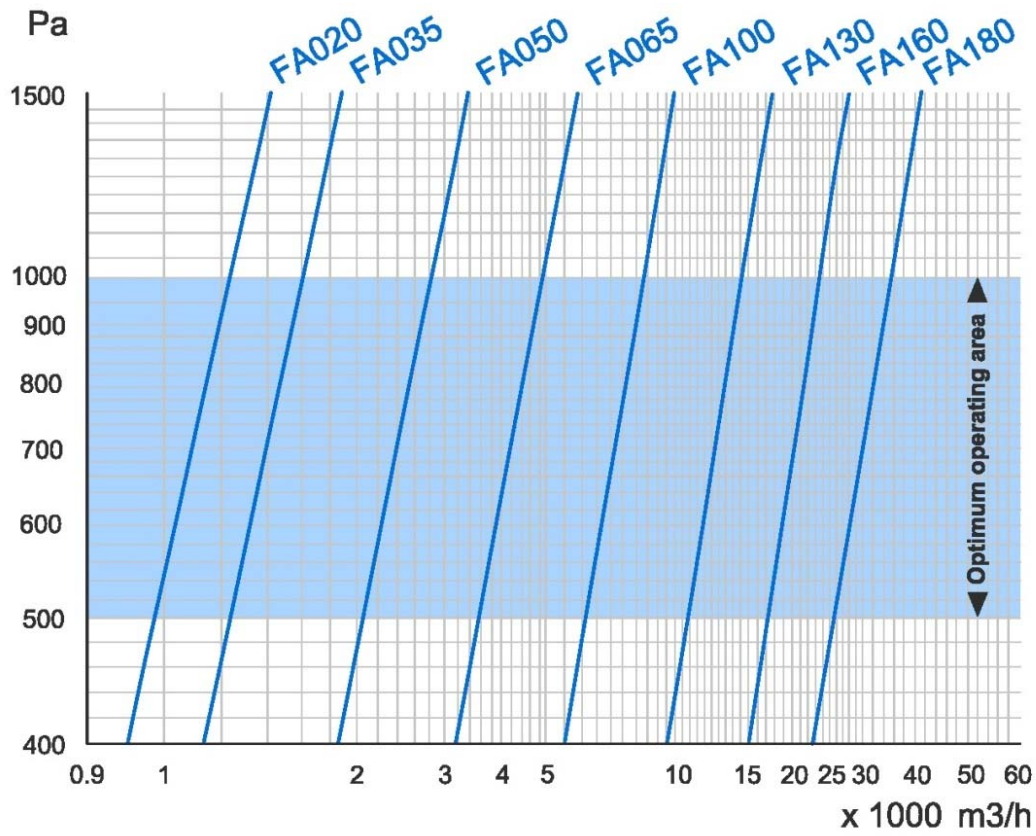

Diagram stating the pressure loss in FA cyclones at a given air volume.

## 2. INTALLATION

The installation of the cyclone has to be performed by qualified personnel only. For heavy parts use the right equipment and do not work alone.

### 2.1. Cyclone installation

**Step 1:** Transport the cyclone to the desiderate place with the help of the lifting eyes.

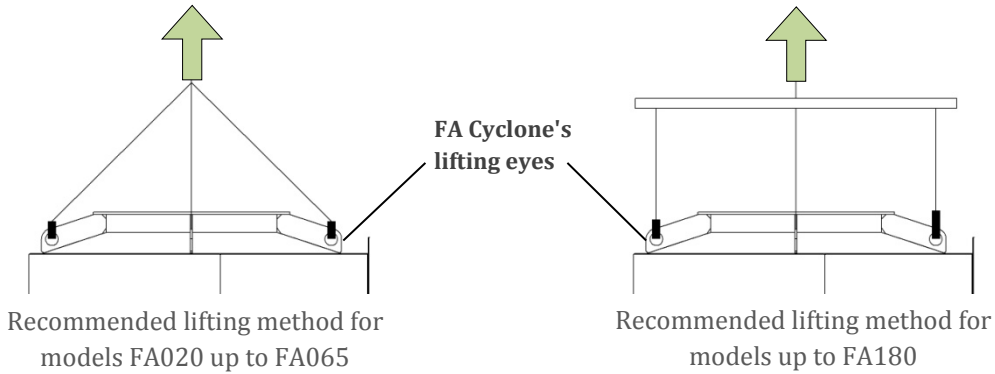

**Step 2:** Use sealing tape on the cyclones rectangular inlet duct and connect it to the duct with the correct fasteners.

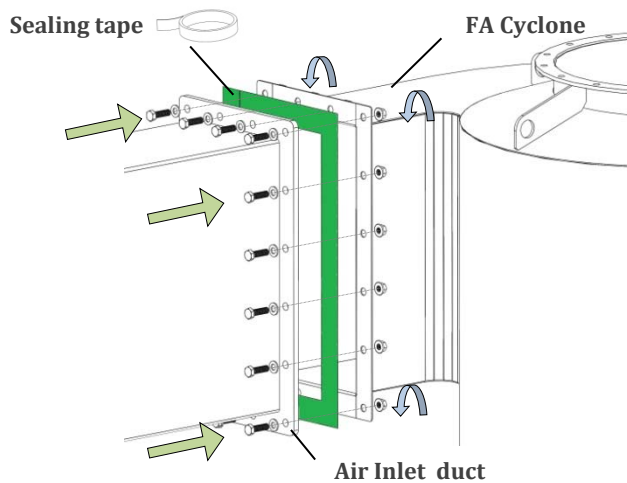

**Step 3:** Use sealing tape on the cyclones higher flange and connect it to the duct with the correct fasteners.

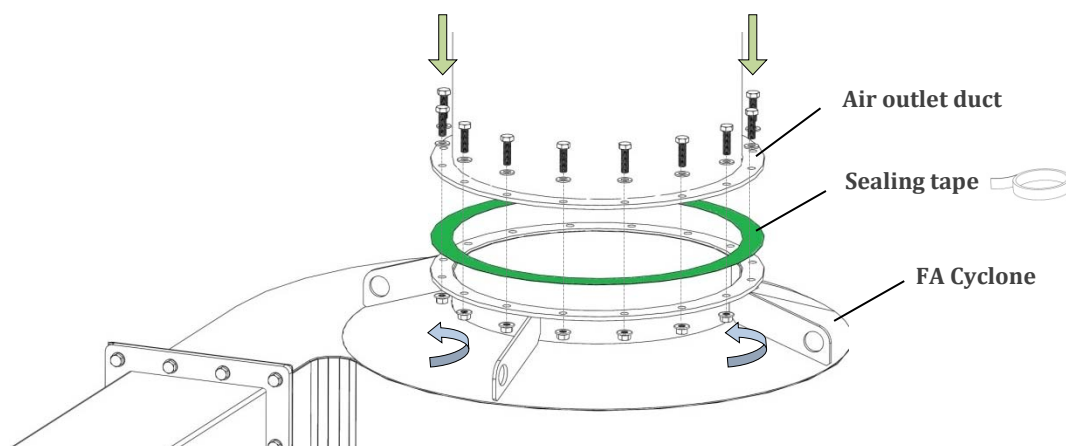

## 2.2. Installing a cyclone with legs

**Step 1:** Please follow the installation steps in *Chapter 2.1.* for cyclone installation.

**Step 2:** Unscrew the bolts where legs are being positioned and position the leg to the bottom part of the cyclone's hopper flange.

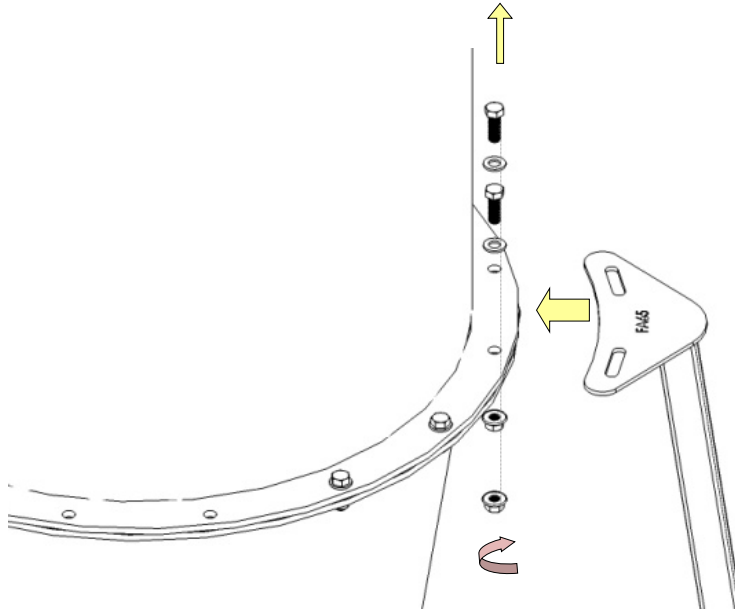

**\*CAUTION!** Make sure each leg is in the right position.

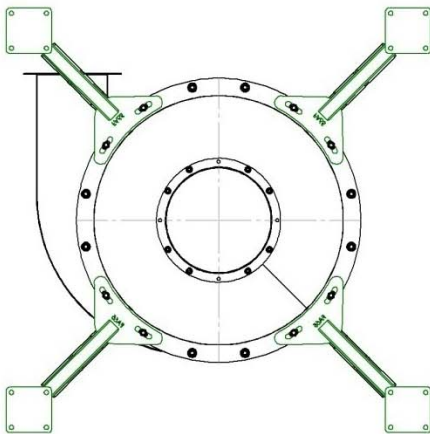

LEG SUPPORT POSITIONING FOR  
FA CYCLONES LEFT SIDE

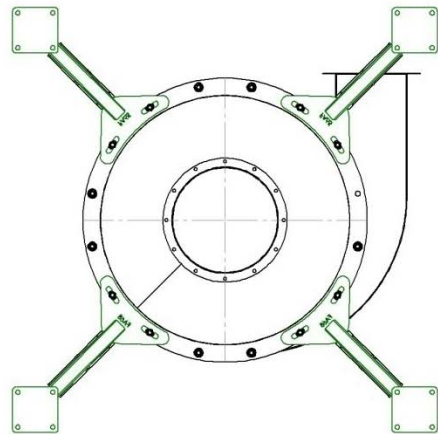

LEG SUPPORT POSITIONING FOR  
FA CYCLONES RIGHT SIDE

**Step 3:** Bolt the top of each leg to the middle flange of the cyclone with the correct fasteners.

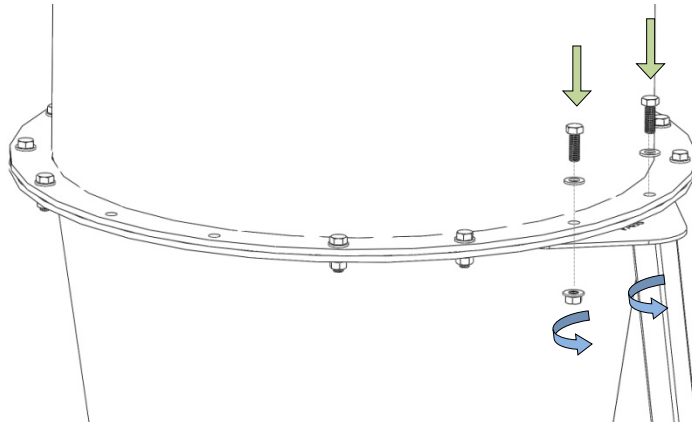

**Step 4:** Repeat Step 2 and Step 3 to attach the other three leg supports.

**Step 5:** Loosen all the fasteners from the lower arm of the leg support.

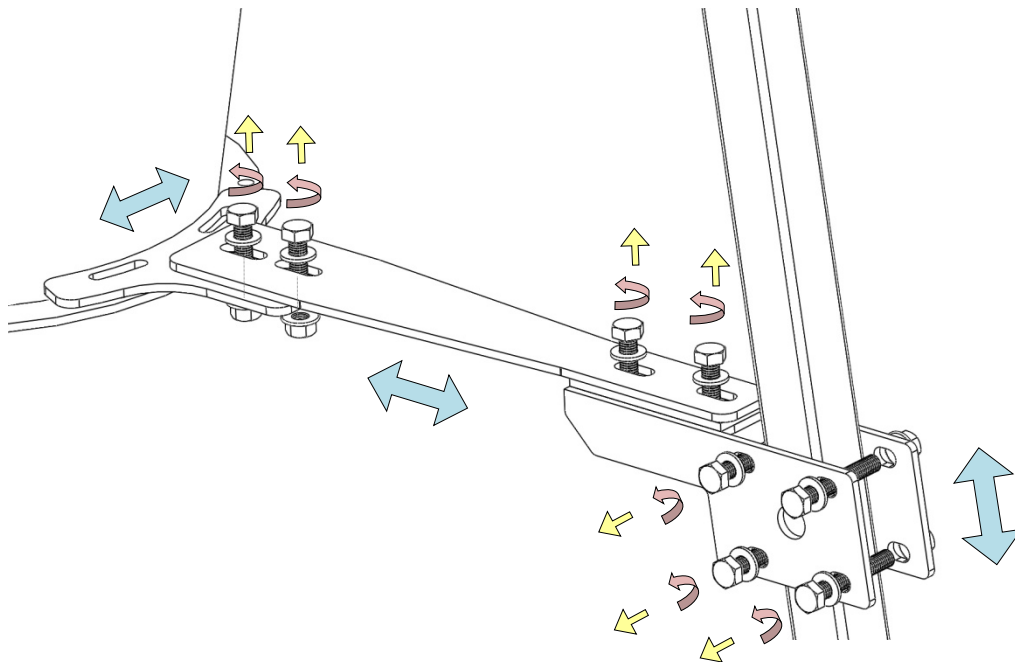

**Step 6:** Attach the lower arm to the cyclone's hopper lower flange with M10 fasteners.

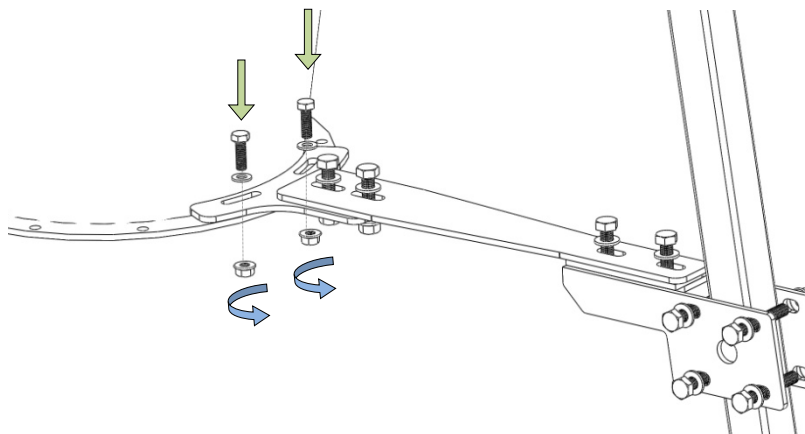

**Step 7:** Tighten all the loose fasteners for a good fixation.

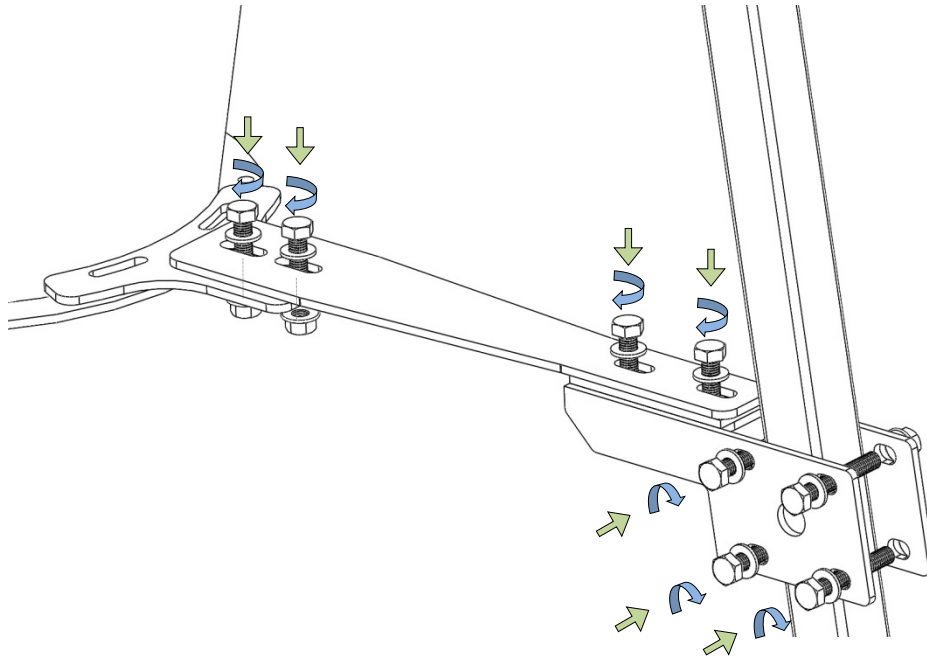

**Step 8:** Repeat the Step 5, Step 6 and Step 7 for the other leg supports.

**Step 9:** Anchor the legs to the floor with the correct fasteners.

### 2.3. Installing the dustbin

**Step 1:** Please follow the installation steps in *Chapter 2.2.* for cyclone and legs installation.

**Step 2:** Remove all fasteners from the lower flange of the cyclone.

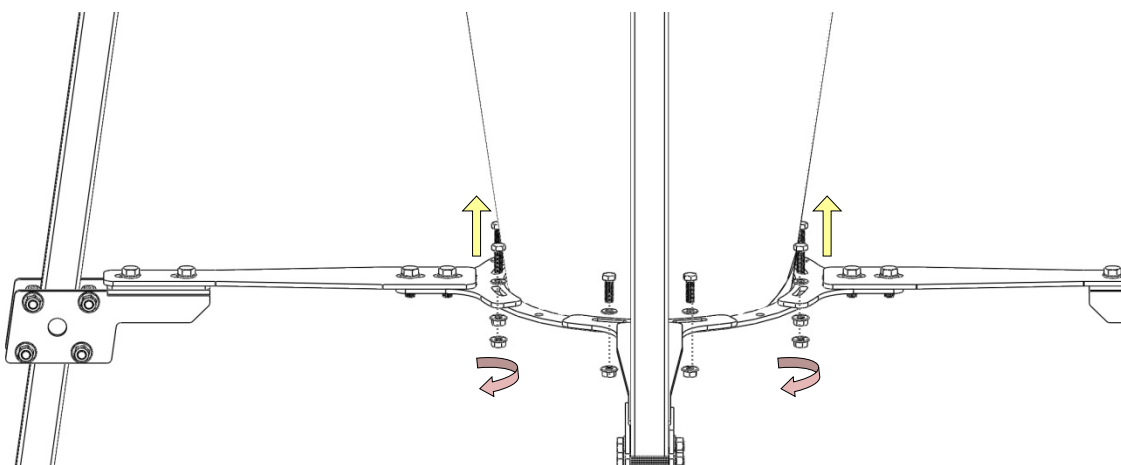

**Step 3:** Use sealing tape on the connector's flange and connect it to the lower flange of the cyclone with the correct fasteners.

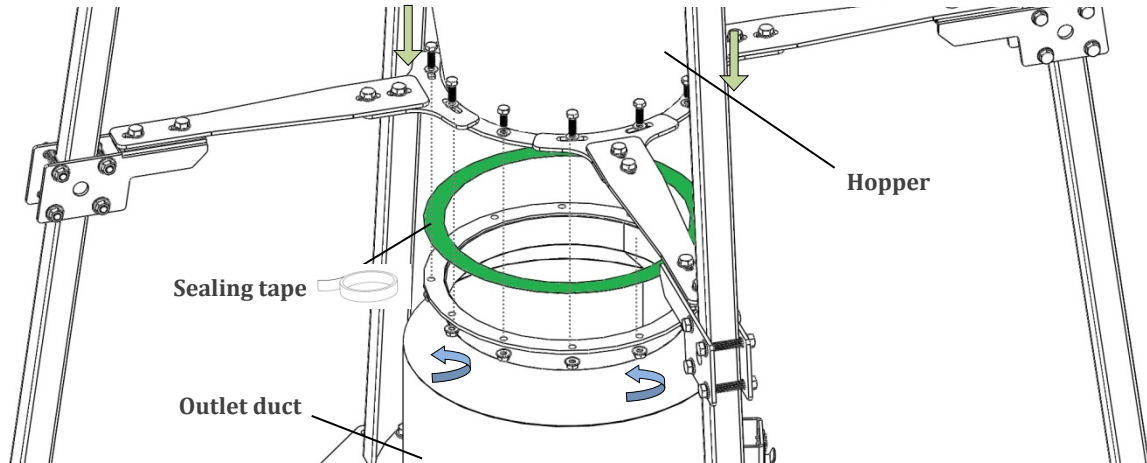

**Step 4:** Fix the dustbin.

*\* For heavy dustbin*

- Lock the dustbin to the transition with the three clamps.

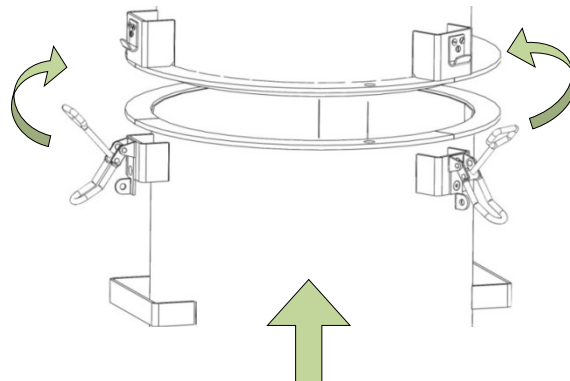

- Screw the bolts to the flange of the dustbin.

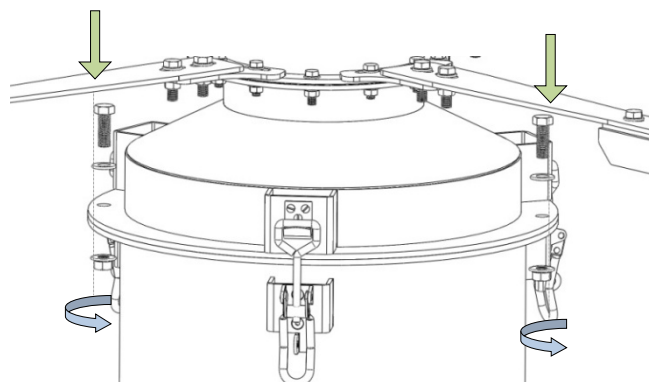



*\* For dustbins with flexible connection*

- Lock the dustbin to the connector with the lock ring.

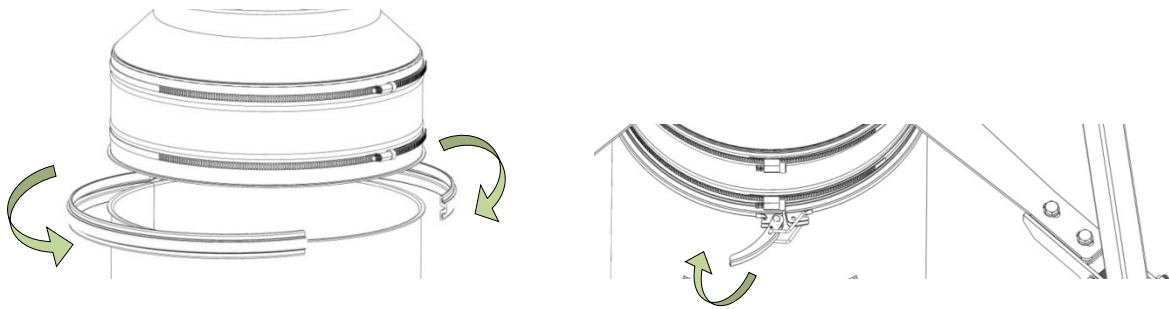

## 2.4. Removing the dustbin

**Step 1:** Unlock the dustbin.

*\* For dustbins with rigid connection*

- Unlock the three clamps from the dustbin.

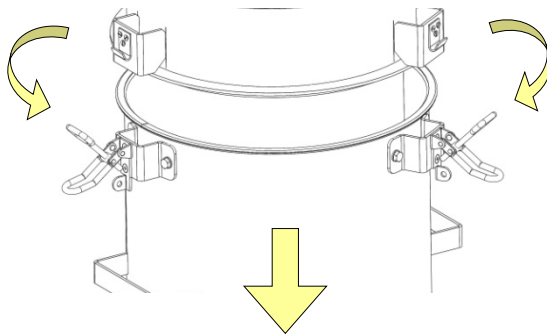

*\* For dustbins with flexible connection*

- Unlock the lock ring which fixes the dustbin to the connector.

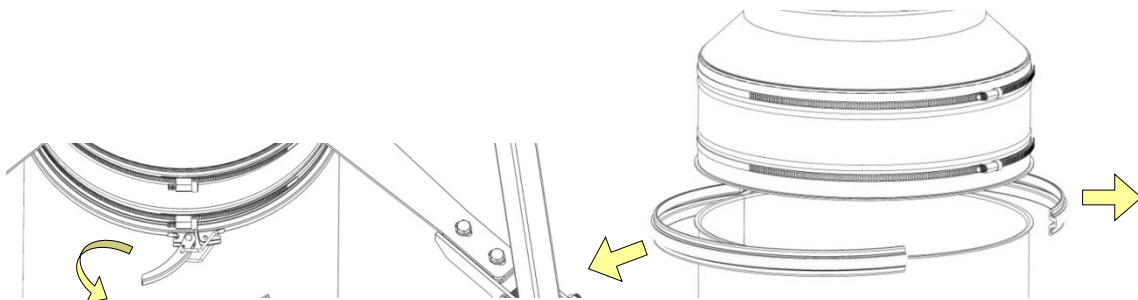

**Step 2:** Roll the dustbin to the desired location and empty its contents.

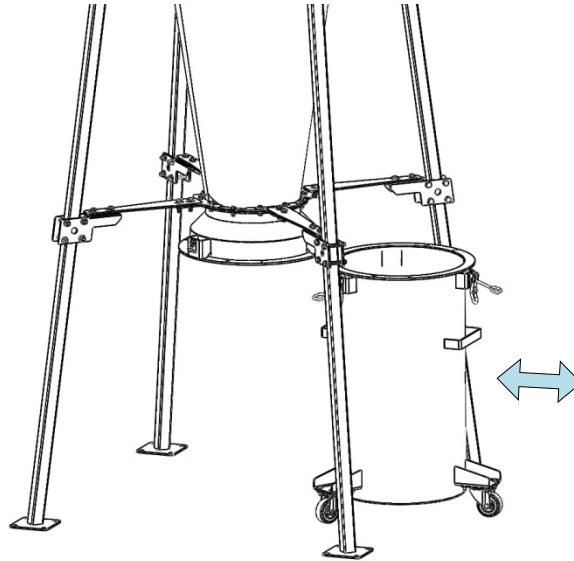

**Step 3:** Fix the dustbin again. Please follow the *Step 4* in *Chapter 2.3*.

## 2.5. Installing the expansion chamber

When using an expansion chamber, extra legs are added under the standard leg support, so that the space left between the floor and the lowest part of the cyclone is always 1 meter.

**Step 1:** Attach the extra leg support to the standard leg support with the correct fasteners. Repeat this step for the other legs.

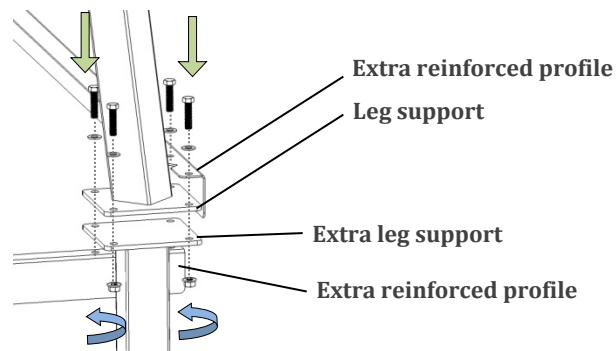

**Step 2:** For the leg support installation, please refer to *Step 2* to *Step 8* in *Chapter 2.2*.

**Step 3:** For the biggest cyclones, place the crosspiece onto the extra leg support's profiles. Use M10 fasteners to attach the crosspiece to the leg support.

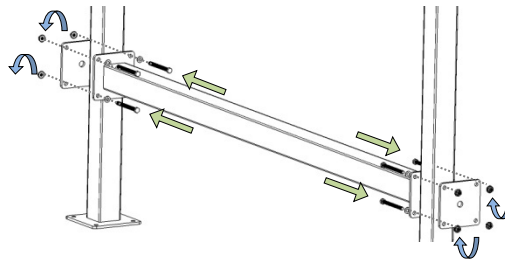

**Step 4:** Anchor the legs and to the floor with the correct fasteners. If necessary, add the extra reinforced profiles that are provided.

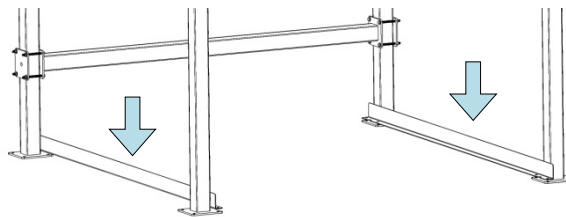

**Step 5:** Attach the expansion chamber by its flange to the lower flange of the cyclone with the correct fasteners.

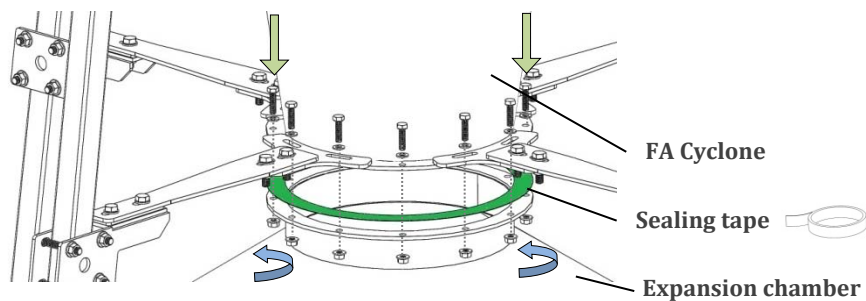

### 3. MAINTENANCE & TROUBLESHOOTING

Clean the cyclone regularly.

If the dust outlet is blocked, please clean the inside of the cyclone.

Replace any components that are damaged or broken.

#### 3.1. Removing the dustbin transition

**Step 1:** Unscrew the fasteners which attach the dustbin transition to the cyclone.

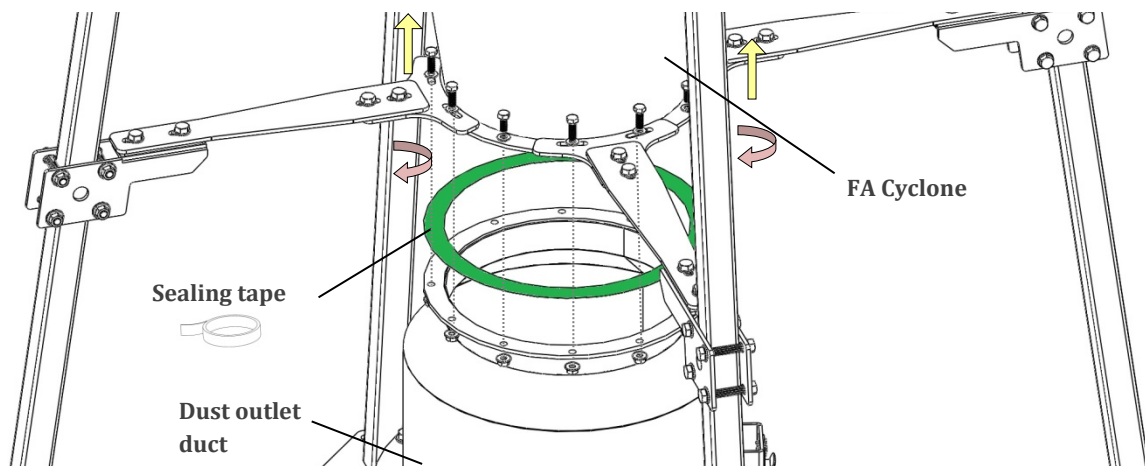

#### 3.2. Replacing the leg support

**Step 1:** Unfix the leg support from the floor.

**Step 2:** Unscrew the leg lower arm from the cyclone dust outlet flange.

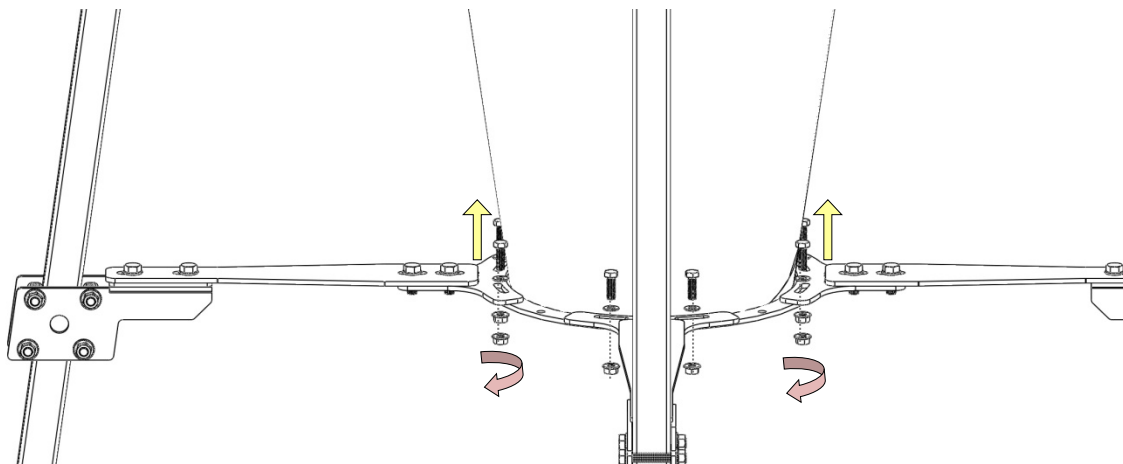

**Step 3:** Unscrew the fasteners from the higher flange of the cyclones hopper. Remove the leg support.

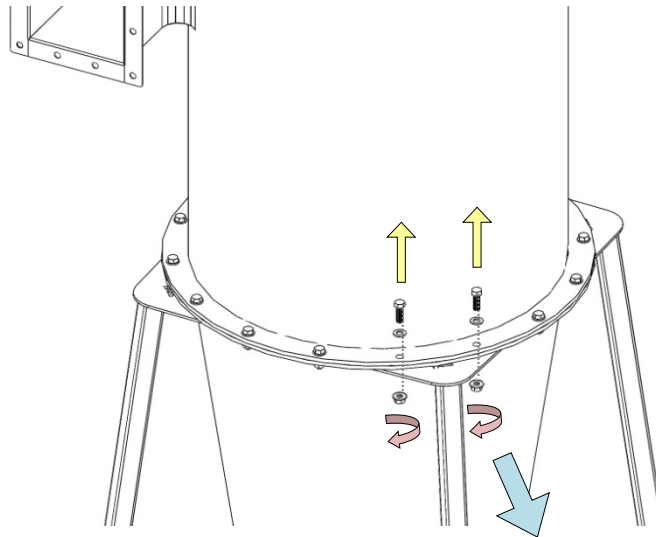

### 3.3. Replacing a cyclone's part

**Step 1:** Unscrew the middle part flanges fasteners.

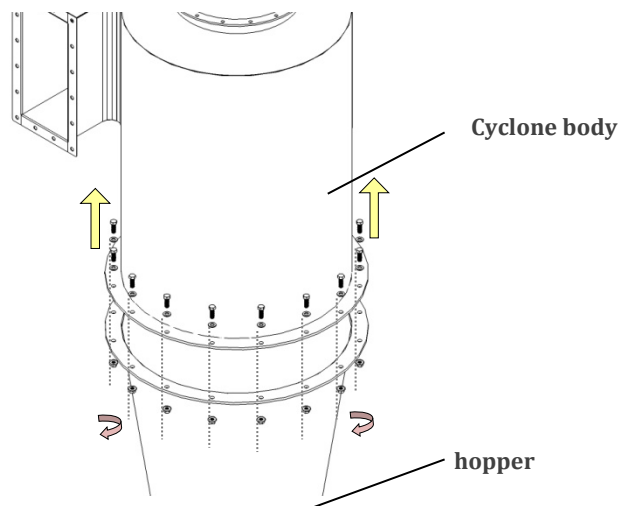

**Step 2:** Replace the cone or the higher part.

**Step 3:** Attach the cyclone with the correct fasteners. Use sealing tape to make it airtight.

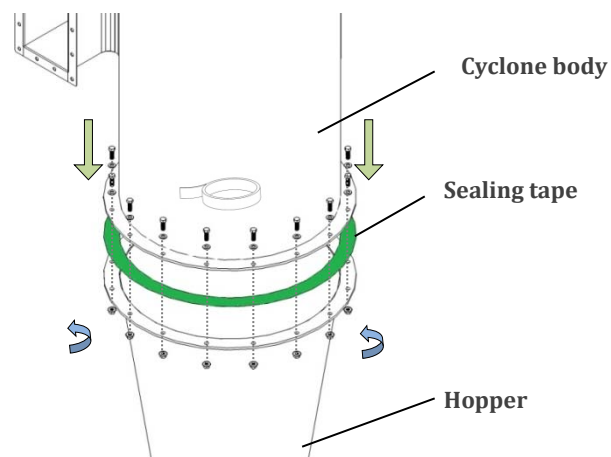

#### 4. DISMANTLING & RECYCLING

When dismantling a unit, be sure to keep in mind the following important information :

As the unit is dismantled, set aside all still functioning parts in order to re-use them on another unit.

You should always separate the different materials depending on their type : iron, rubber, oils, greases, etc...

Recyclable parts must be disposed of in the appropriate containers or brought to a local recycling company.

The rubbish must be collected in special containers with appropriate labels and disposed of in compliance with the national laws and/or local legislations in force.

**CAUTION!** It is strictly forbidden to dispose of toxic wastes in municipal sewerage and drain systems. This concerns all oils, greases, and other toxic materials in liquid or solid form.

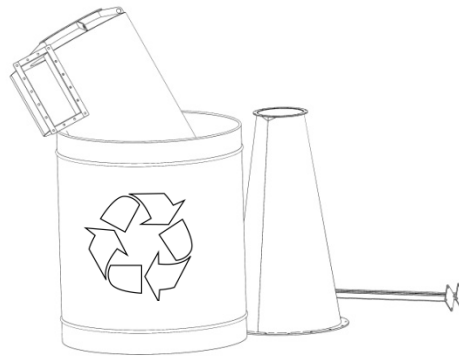

## 5. SPARE PARTS

For spare parts please contact Formula Air Group.

### **Formula Air The Netherlands**

Boscheweg 36  
SX 5741 Beek en Donk  
The Netherlands  
Tel: +31 (0) 492 45 15 45  
Fax: +31 (0) 492 45 15 99

[info-nl@formula-air.com](mailto:info-nl@formula-air.com)  
[view Google Map](#)

### **Formula Air Belgium**

Rue des Dizeaux 4  
1360 Perwez  
Belgium  
Tel: +32 (0) 81 23 45 71  
Fax: +32 (0) 81 23 45 79

[info-be@formula-air.com](mailto:info-be@formula-air.com)  
[view Google Map](#)

### **Formula Air Baltic**

Televizorių G.20  
LT-78137 Šiauliai  
Lithuania  
Tel: +370 41 54 04 82  
Fax: +370 41 54 05 50

[info-lt@formula-air.com](mailto:info-lt@formula-air.com)  
[view Google Map](#)

### **Formula Air France**

Zac de la Carrière Doree  
BP 105, 59310 Orchies  
France  
Tel: +33 (0) 320 61 20 40  
Fax: +33 (0) 320 61 20 45

[info-fr-nord@formula-air.com](mailto:info-fr-nord@formula-air.com)  
[view Google Map](#)

### **Formula Air Est Agence France**

2, rue Armand Bloch  
25200 Montbéliard  
France  
Tel: +33 (0) 91 381 70 71  
Fax +33 (0) 381 31 08 76

[info-fr-est@formula-air.com](mailto:info-fr-est@formula-air.com)  
[view Google Map](#)

### **Formula Air France Agence Ouest**

19a rue Deshoulières  
44000 Nantes  
France  
Tel. +33 (0) 89 251 90 75  
Fax +33 (0) 251 89 94 06

[info-fr-ouest@formula-air.com](mailto:info-fr-ouest@formula-air.com)  
[view Google Map](#)

### **Formula Air France Agence Sud**

Chemin de Peyrecave  
09600 Regat  
France  
Tel: +33 561 66 79 70  
Fax: +33 567 07 01 09

[info-fr-sud@formula-air.com](mailto:info-fr-sud@formula-air.com)  
[view Google Map](#)

### **Air Formula Russia**

Нижний Новгород  
Россия  
Tel: +7 (499) 609 23 54  
Fax: +7 (831) 277 85 38

[info-ru@formula-air.com](mailto:info-ru@formula-air.com)  
[View Google Map](#)

### **Formula Air Vietnam**

# 33, Lot 2, Den Lu 1  
Hoang Mai District, Hanoi,  
Vietnam  
Tel: +84 (4) 38 62 68 01  
Fax: +84 (4) 38 62 96 63

[info@vinaduct.com](mailto:info@vinaduct.com)  
[www.vinaduct.com](http://www.vinaduct.com)  
[View Google Map](#)

NOTE : All drawings and references contained within this manual are non-contractual and are subject to change without prior notice at the discretion of the Formula Air group and its partners.