



BADA-VEX

ATEX non-return valves

Maintenance manual (EN)

V1.2-2023

Table of content

1.	Introduction	4
2.	Preamble.....	4
3.	Safety information.....	4
4.	Standards and certificates.....	5
4.1.	BADA-VEX range is according to following standards :.....	5
4.2.	Manufactured according to quality standards :.....	5
4.3.	Conformity of complementary standard :.....	5
5.	Working features	5
5.1.	BADA-VEX range: DN 160 to DN800 (DN 6" to DN 32").....	5
5.2.	Working airflow: Under-pressure airflow (pull flow).....	5
5.3.	BADA-VEX installation features (Tab-1) :.....	6
6.	BADA-VEX working	6
6.1.	Airflow rules :	6
6.2.	Explosion risk direction :.....	7
6.3.	BADA-VEX working modes:	8
6.4.	Setting of working mode :.....	9
6.4.1.	Floating flap mode :	9
6.4.2.	Flap kept open mode by mechanic system :.....	10
6.4.3.	Flap position indicator, when it's opened :	12
6.4.4.	Flap position in idle position (only for floating flap mode) :.....	12
6.4.5.	Flap indicator in waiting position :.....	13
6.4.6.	Flap locked in closed position :.....	13
6.4.7.	Indicator position with flap locked closed :.....	14
7.	Installing the BADA-VEX.....	14
7.1.	Rules to install the BADA-VEX :	14
8.	Overall dimensions (The list of models is not exhaustive)	19
8.1.	BADA-VEX range in metric « DN » (TAB-4).....	19
8.2.	BADA-VEX range in imperial « DN » (TAB-5).....	20
9.	Flap locking sensor (in closed position).....	20
9.1.	Inductive sensor Ø12 non-ATEX zone (DN≤350 - DN≤14") :.....	21
9.2.	Optional : inductive sensor Ø12 for ATEX zone -  (DN≤350 - DN≤14") :.....	21
9.3.	Inductive sensor Ø18 non-ATEX zone (DN≥400 - DN≥16") :.....	22
9.4.	Optional : inductive sensor Ø18 for ATEX zone -  (DN≥400 - DN≥16") :.....	22
10.	Dust build-up sensor.....	22
10.1.	Capacitive sensor Ø12 for ATEX zone -  :.....	24
11.	ATEX marking.....	25
11.1.	Certification features :	25
11.2.	Scope of the standards present on product marking :.....	25
11.3.	Marking example :	25
12.	Aeraulic pressure loss	26

12.1.	Pressure loss graphs.....	26
12.2.	Pressure loss values (in mm H ₂ O /inch Wg) measured at 20 m/s (4000 ft/min) (TAB-8).	27
13.	Maintenance operations and periodic inspections.....	28
13.1.	Standard requirements :.....	28
13.2.	Periodic inspection operations :	28
13.3.	Check all following points (TAB-9):.....	29
13.4.	Procedure in case of an explosion :	29
14.	Dismantling and recycling	30
15.	Maintenance log	31
	Contacts.....	32

1. Introduction

This manual cannot be reproduced, even partially, without prior written consent by Formula Air Group. Every step of the ATEX non-return valve range has been deeply analyzed by Formula Air Group in the expected area during the design, construction, and user manual creation. However, it is understood that nothing can replace the experience, training and good sense of those professionals who work with the device.

Ignoring the cautions and warning from the present user manual, using improperly parts or the whole device supplied, using unauthorized spare parts, manipulating the device by non-qualified personnel, violation of any safety norm regarding design, construction and use expected by the supplier, exempt Formula Air Group from all responsibility in case of damages to people or properties.

Formula Air Group does not take any responsibility for the non-observance of the user about the preventive safety measures presented in this user manual.

Failure to comply with the requirements of the user manual or incorrect use of the ATEX non-return valve during operation can lead to the damage of the ATEX non-return valve and improper functioning of the ATEX non-return valve itself. This will result in termination of the warranty on the item and will release the manufacturer from any liability.

Certification

The BADA-VEX non-return valve range is conform to ATEX norms EN16447 & EN15089.

Warranty : Refer to the general sales condition in regards to the device's warranty.

Attention !

All drawings and references contained within this user manual are non-contractual and are subject to change without prior notice at the discretion of the Formula Air Group and its partners.

Copyright © Formula Air.

2. Preamble

Before proceeding to the installation of the valve, please read carefully the following instructions.



Warning :

All instructions contained within this manual have to be fully understood and absolutely followed in order to guarantee the proper functioning of the BADA-VEX ATEX non-return valve. If you have any questions, especially in specific applications, please contact FORMULA AIR.

3. Safety information

The BADA-VEX is a protection device for dust ATEX zone (EX II D). The facility manager has to implement the European regulation 1999/92CE. To be sure that this device is correctly used, the authorized workers have to be trained on the warning signs and safety rules to ensure the safety of people and facilities.



Non-return valve safety rules according to the standards EN 16447. The explosion isolation non-return valves have not to be used to protect installations with the following substances, nor a mixture containing some of these substances:

- a) Gas, steams or hybrid mixing
- b) Unstable chemical substances
- c) Explosive substances
- d) Pyrotechnic substances



It is mandatory to respect the pipe length between the protected vessel and the BADA-VEX according to minimum (Lmin) and maximum length (Lmax) to assure the BADA-VEX isolation in case of explosion.

The vessel(s) connected to the BADA-VEX must be protected :

- Either by an explosion venting device (vent panel, flameless)
- Or a suppression system



BADA-VEX is designed to isolate a vessel with a pressure resistance of ≤ 0.5 bar (Pred). In case the vessel has a higher resistance, the explosion discharge device has to be defined with maximum reduced pressure in it of (Pred) ≤ 0.5 bar. The pipes before and after the BADA-VEX need to resist to 2 bar (like the BADA-VEX).



Don't use the BADA-VEX to support the pipes upstream or/and downstream. It should not be subjected to strong vibration to keep its isolation integrity in case of explosion.



Assure the electrical continuity of the installation (earthing) by connecting the BADA-VEX with earth wires to both pipes.

4. Standards and certificates

4.1. BADA-VEX range is according to following standards :

- 2014/34/UE ATEX regulation
- EN 16447 : 2014 Explosion isolation flap valves
- EN 15089 : 2009 Explosion isolation systems
- EN 1127-1 :2019 Explosion prevention and protection - Part 1
- EN 14460 : 2018 Explosion resistant equipment



4.2. Manufactured according to quality standards :

- 0080 N° of notified body in charge of checking (INERIS)
- INERIS 23ATEX0012X N° of EU type examination certificate



4.3. Conformity of complementary standard :

- NFPA 69 : 2019 Explosion Prevention Systems



5. Working features

BADA-VEX is an ATEX protective device equipped with a mobile flap which will close under explosion overpressure and will lock in closed position to avoid the flame to propagate through the ducting to another part of the facility (suction inlet, filter...).

BADA-VEX is certified for PUSH and PULL flow installations.

BADA-VEX seal the pipe to stop explosion from spreading, either if the explosion come from in opposite direction of the air + dust flow (example: see picture 1, page 5: "position **A**") or if the explosion come from the direction of the clean airflow (example: see picture 2, page 5: "position **D**"). In this second case, you need to use the non-return valve with the flap locked in open position.



Working limits of the BADA-VEX range are defined to ensure the safety of workers, equipment and the installation. Upholding these limits are the responsibility of the Management exploiting the premises.

5.1. **BADA-VEX range:** DN 160 to DN800 (DN 6" to DN 32")

5.2. **Working airflow:** Under-pressure airflow (pull flow)
Over-pressure airflow (push flow)

- Bends are allowed upstream and downstream of the BADA-VEX, no quantity limit or position restrictions,
- The BADA-VEX can be installed in vertical position (Pictures 15 + 16)

Kst,max	≤250 bar.m/s	Pred,max *	≤ 0.5 bar	Airflow speed	Clean air side : ≤ 30 m/s Loaded air side : ≤ 45 m/s
Kst,min	No limit	BADA-VEX resistance	2.0 bar	Placement	Air & dust ducting Clean air ducting
Pmax	10 bars	ATEX marking	 II D	Airflow range	Under-pressure : Pull flow Over-pressure : Push flow
MIE	≥ 10 mJ	ATEX inside	Zone 20 (II 1 D)	Over-pressure limit	500 mbar max
MIT	≥ 400°C	Dust type**	All dust types	Under-pressure limit	- 800 mbar max
MESG	1.7 mm	Dust concentration	No limit	Qty.of bends	No limit

* Vessel (potential explosion source)

** Organic dust, synthetic dust or metal dust according to the limits defined above.

Working temperature	
Standard : flap gasket in EPDM	-30°C to +70°C / -22°F to 158°F
Option : flap gasket in SILICONE	-10°C to +180°C*** / 14°F to 356°F***

***Caution: With standard sensor, the working temperature is limited to 70°C / 158°F. Option is available up to 150°C/302°F only for locking sensor.

5.3. BADA-VEX installation features (Tab-1) :

DN		Vmin	Lmin	Lmin +2m	Lmax
Ø160	(6")	0,70 m ³	4,0 m	6,0 m	17 m
Ø160	(6")	1,35 m ³	3,0 m	5,0 m	17 m
Ø180	(7")	0,70 m ³	4,0 m	6,0 m	17 m
Ø180	(7")	1,35 m ³	3,0 m	5,0 m	17 m
Ø200	(8")	1,35 m ³	4,6 m	6,6 m	17 m
Ø250	(10")	1,35 m ³	4,0 m	6,0 m	17 m
Ø300	(12")	2,90 m ³	4,6 m	6,6 m	17 m
Ø350	(14")	2,90 m ³	4,2 m	6,2 m	17 m
Ø400	(16")	4,50 m ³	5,2 m	7,2 m	17 m
Ø450	(18")	4,50 m ³	4,7 m	6,7 m	17 m
Ø500	(20")	6,05 m ³	5,8 m	7,8 m	17 m
Ø550	(22")	6,05 m ³	5,5 m	7,5 m	17 m
Ø600	(24")	7,65 m ³	7,2 m	9,2 m	17 m
Ø650	(26")	7,65 m ³	6,7 m	8,7 m	17 m
Ø700	(28")	7,65 m ³	6,4 m	8,4 m	17 m
Ø750	(30")	10,00 m ³	7,3 m	9,3 m	17 m
Ø800	(32")	10,00 m ³	6,9 m	8,9 m	17 m

Vmin : Min vessel volume being protected by BADA-VEX isolation valve.

Lmax : Max installation distance between the vessel and the BADA-VEX.

Lmin : Min installation distance between the vessel and BADA-VEX, for floating flap with straight horizontal pipe, no bends.

Lmin + 2 m : Min installation distance between the vessel and BADA-VEX in at least one of following cases :

- Flap locked open by its spring system,
- Pipe with bend between isolated vessel and BADA-VEX, flap in horizontal position $\pm 10^\circ$ (see picture 18),
- Pipe with bend between isolated vessel and BADA-VEX, flap in vertical position, observe following rules :
 - Min installing distance = Lmin+2m, if vertical pipe from bend to BADA-VEX $> 5 \times \text{Øpipe}$,
 - Or
 - Min installing distance = Lmin+2m +5 $\times \text{Ø}$, if vertical pipe from bend to BADA-VEX = 5 $\times \text{Øpipe}$.



Installation of BADA-VEX in vertical position must be with vertical pipe of min 5 $\times \text{Øpipe}$ between bend and BADA-VEX (see picture 16).

6. BADA-VEX working

6.1. Airflow rules :

BADA-VEX is certified to work with under-pressure airflow (Pull flow) or over-pressure airflow (Push flow).

BADA-VEX can be installed in position A and B (picture 1) on the LOADED air side or in position D and E (picture 2) on the CLEAN air side. In position D and E the BADA-VEX needs to be locked open with the mechanical system.

The working direction of airflow (Push flow or Pull flow) has no influence on the min installation distance.



The working position D and E are advised to inject back the clean air inside the workplace. It's recommended to not use the position C (picture 3) and F (picture 4).

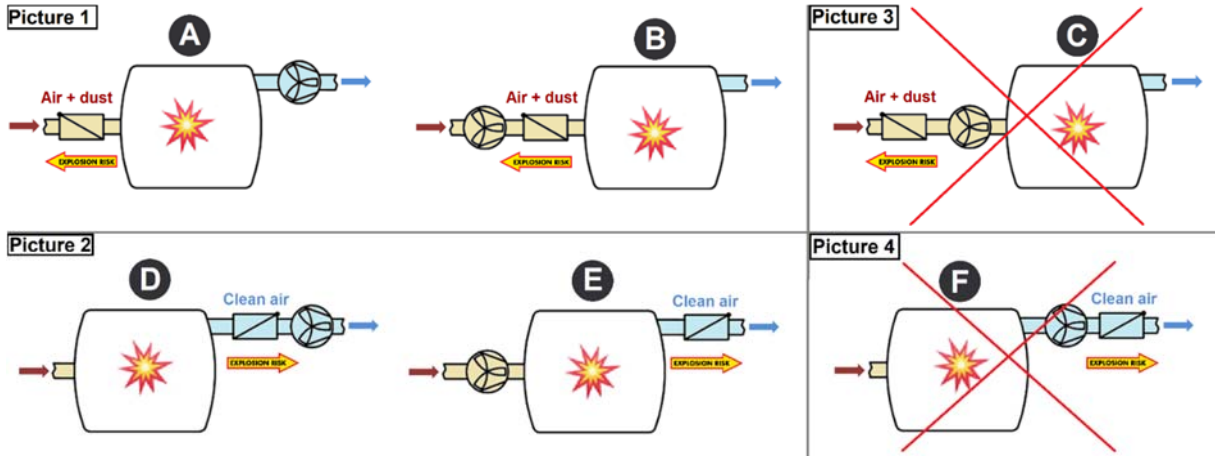

6.2. Explosion risk direction :

 BADA-VEX installation must observe the direction of the "EXPLOSION RISK" arrow. In fact, this arrow indicates the direction of explosion flame which has to be stopped by the BADA-VEX, not the normal working airflow.

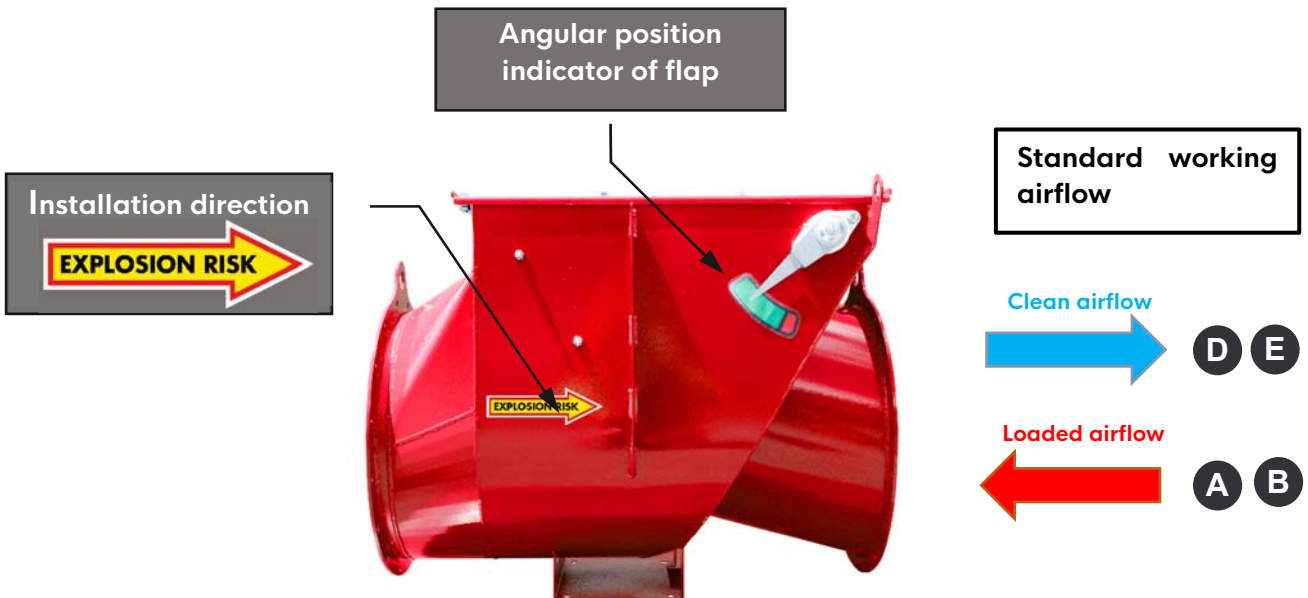

6.3. BADA-VEX working modes:



BADA-VEX can function following 2 modes: either with floating flap (picture 5) or flap kept open (picture 6). According to the chosen mode, you have to observe the installation distance L_{min} and L_{max} . These values have to be checked following the chosen mode as well as the volume of vessel with potential explosion risk (see Tab-1 page 4).

Floating flap mode, the flap is opened by the working airflow. When the fan stops, the flap closes itself by its weight without locking (wait to open).

Kept open flap mode, flap is kept open by strip spring system in max opened position. In this mode, the BADA-VEX can be installed on the clean air side. The kept open flap position can support air speeds up to 30 m/s (6000 ft/min) without closing. It also can be installed in loaded air to reduce the pressure drop especially with low airflow speeds.

We advise using BADA-VEX in floating flap mode when it's installed in loaded airflows (working flow in opposition direction of explosion). However, BADA-VEX has to be used in keep opened flap mode when it's installed on the clean air side (explosion flame in same direction than working flow) according to direction of explosion risk.

Picture 5

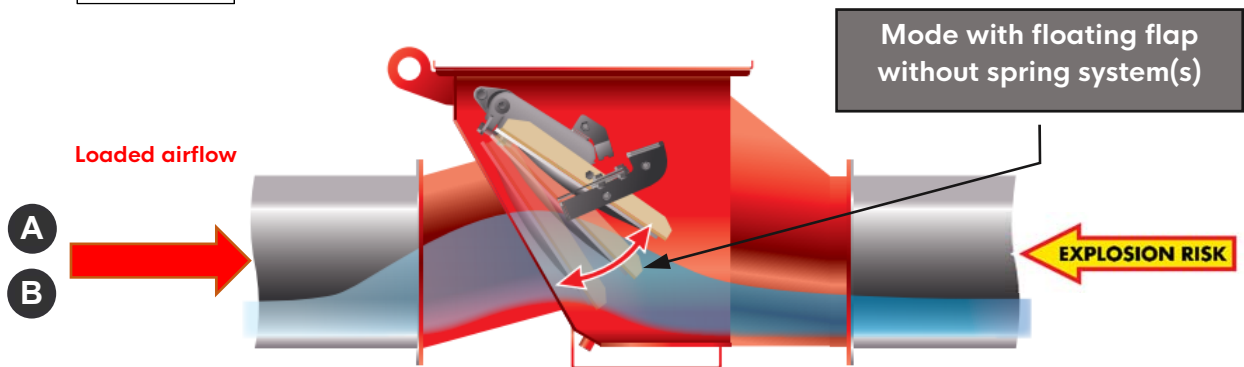

Picture 6

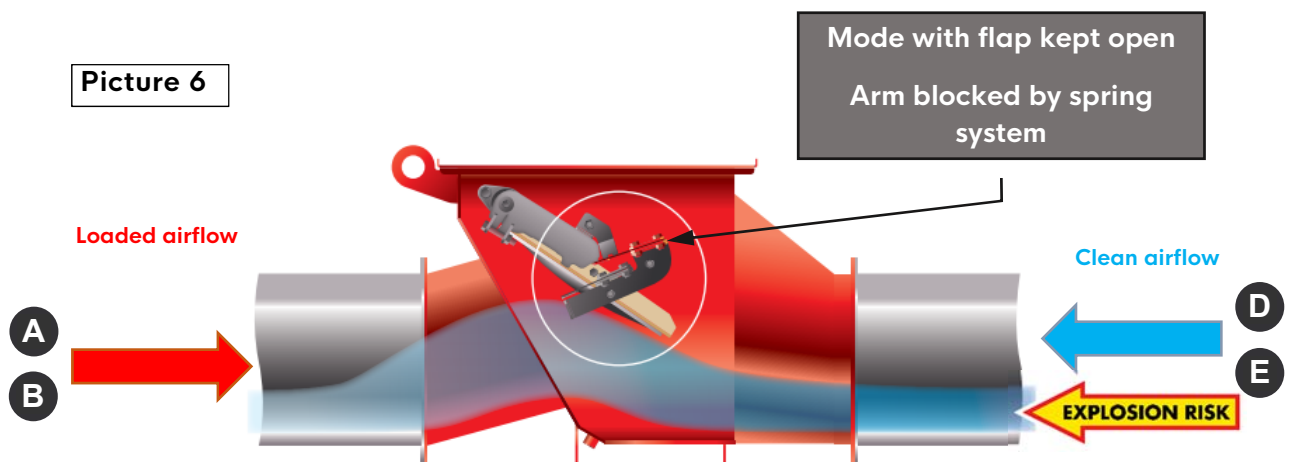

i Only the overpressure of an explosion is capable of activating the locking system of the valve.

The arm of the flap is locked in closed position by the mechanical locking system

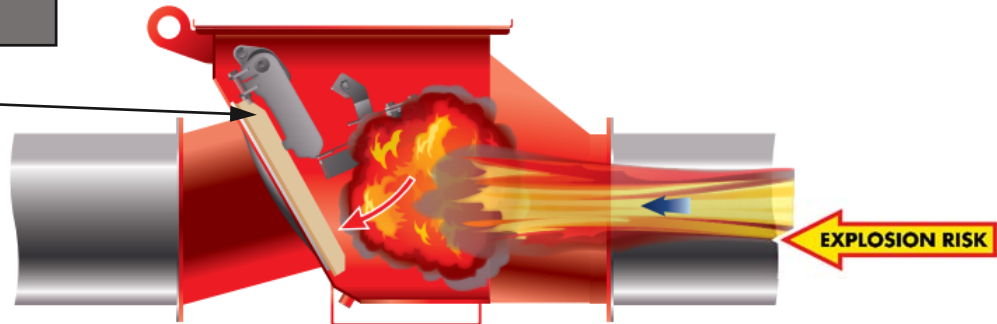

6.4. Setting of working mode :



The BADA-VEX is delivered from the factory in the 'Locked Open' position. If you want to use the BADA-VEX with a 'Floating Flap' remove the external protection cover and take the following measures :

Be sure that the installation is switched off before operating on the BADA-VEX and remove the protect cover.

6.4.1. Floating flap mode :

To set up the BADA-VEX in mode : floating flap, you have to take off the spring strip to allow the flap to move freely (picture 7 and 7b).



Caution : the outside arm is part of the moving parts. The weight of this subassembly is high for the BADA-VEX \geq DN 400 (16"). Be especially careful when handling it, don't put your hand either in the moving zone nor in the gasket zone of the flap inside the body.

Picture 7

BADA-VEX floating flap mode DN160 (6") to DN450 (18")

Remove the following parts :

- A) Spring strip
- B) Pin
- C) Bolt and screw
- D) Pin lock
- E) Locked open leaf spring

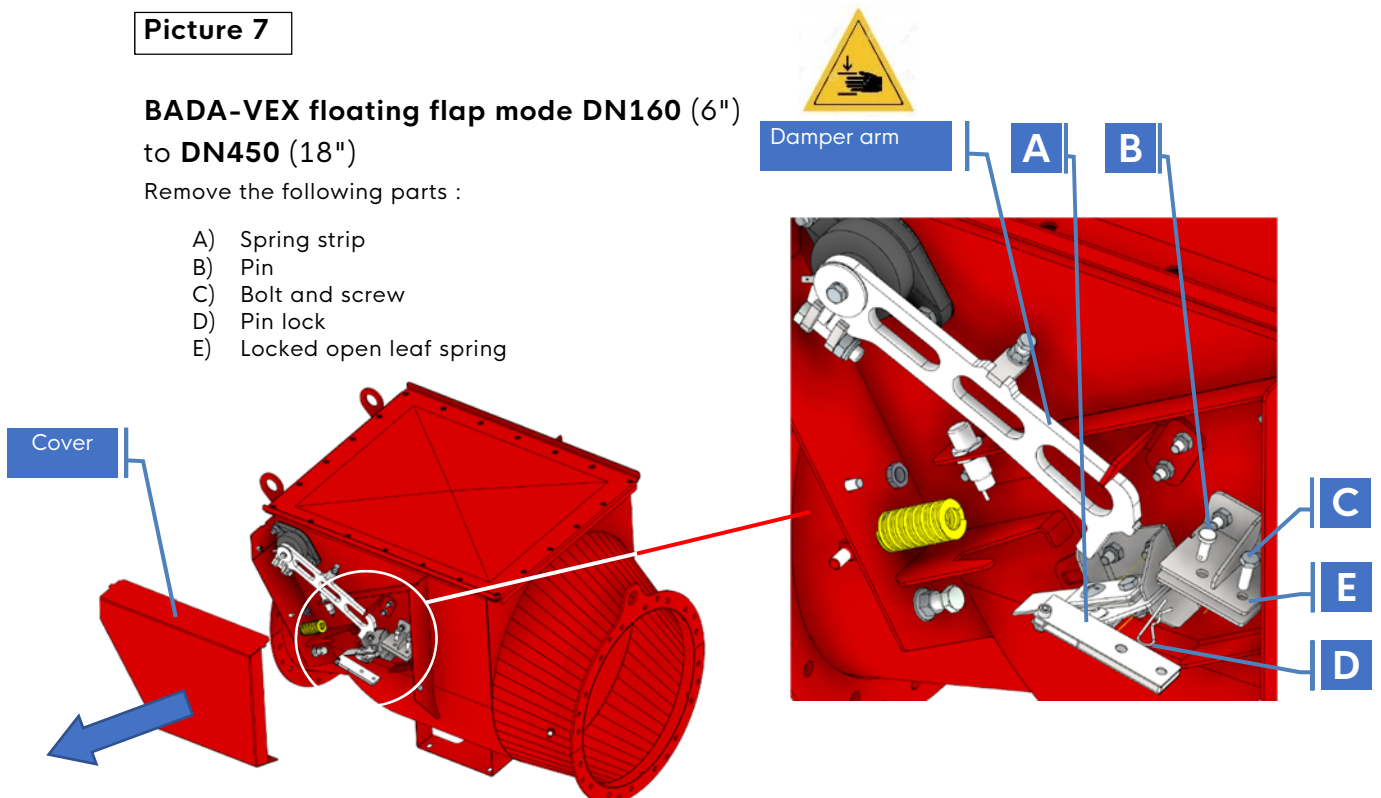

Picture 7b

**BADA-VEX floating flap mode DN500 (20")
to DN800 (32")**

Remove the following parts :

- A) 2 spring strips
- B) 2 pins
- C) 2 bolts and nuts
- D) 2 pin locks
- E) Locked open leaf springs

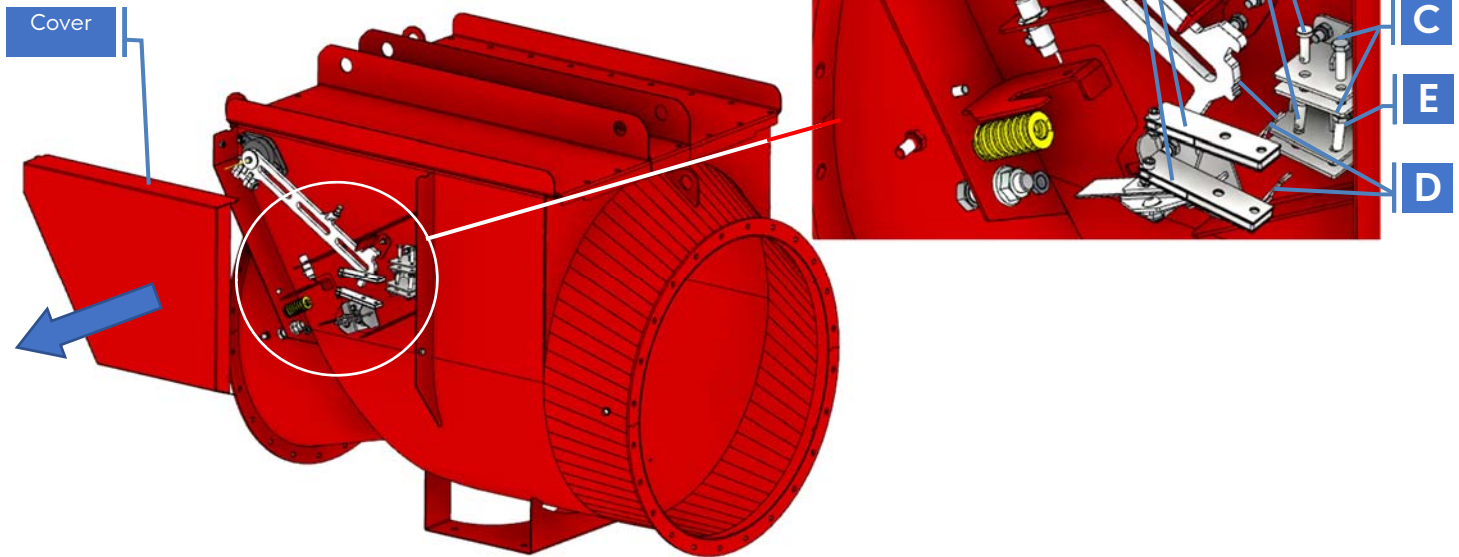

6.4.2. Flap kept open mode by mechanic system :



The BADA-VEX is delivered from factory in mode: Flap kept open by mechanic locked system. If you have to change the working mode into floating flap position, to set back the BADA-VEX in flap « locked open position” mode or to place again the flap in kept open position, you have to take off the protection cover and undertake the following operations :

1. To set back on mode: flap kept open by mechanic system, you have to put in place the spring strip(s) ref. A on the bracket(s) ref. E operate in opposite way as described in the pictures 7 or 7b. Then tighten the bolt to 5 Nm and loosen by a ¼ turn.
2. To place again the flap in kept open position by mechanic system (picture 8 and 8b). Step 1, you have to turn the spring strip(s) ref. A to outside position in order to raise the arm against the top stop part ref. F. Step 2, you have to turn back the spring strip(s) under the outside arm and slowly release the arm. Now, you have to lock the spring strip(s) in position with the pin ref. B and pin lock ref. D.



It's forbidden to use the BADA-VEX without protection cover.
You have to put the cover back in place with fixing screws after each operation.

Picture 8

BADA-VEX flap kept open by mechanic system

1er step: raise the arm against the top stop part

Example of BADA-VEX DN≤500 (20") with double spring strips.

Operation is the same for all other sizes, only difference about spring strip number.

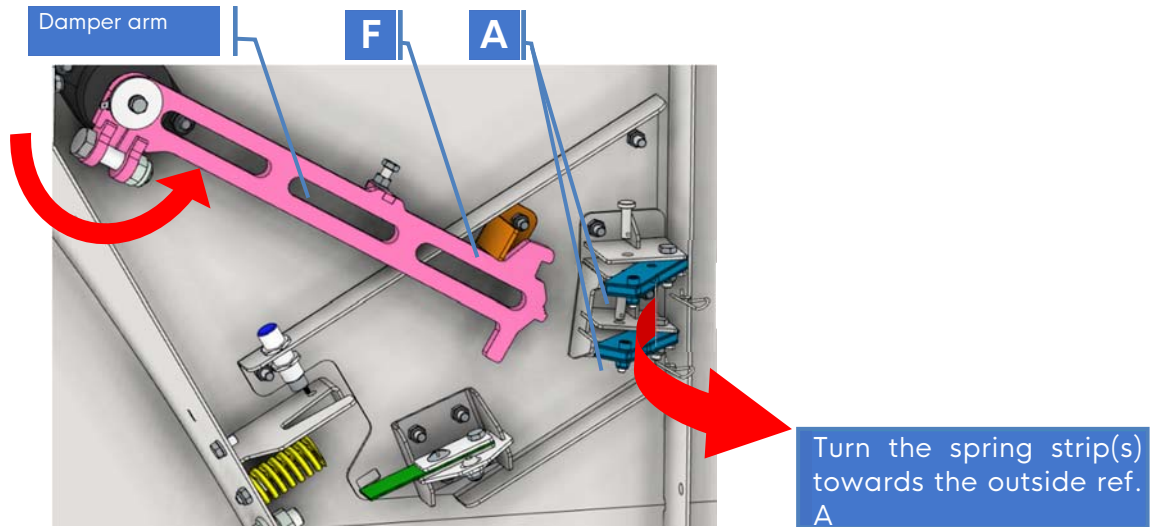

Picture 8b

2nd step:
lock the blocking system of the damper arm (and the flap)

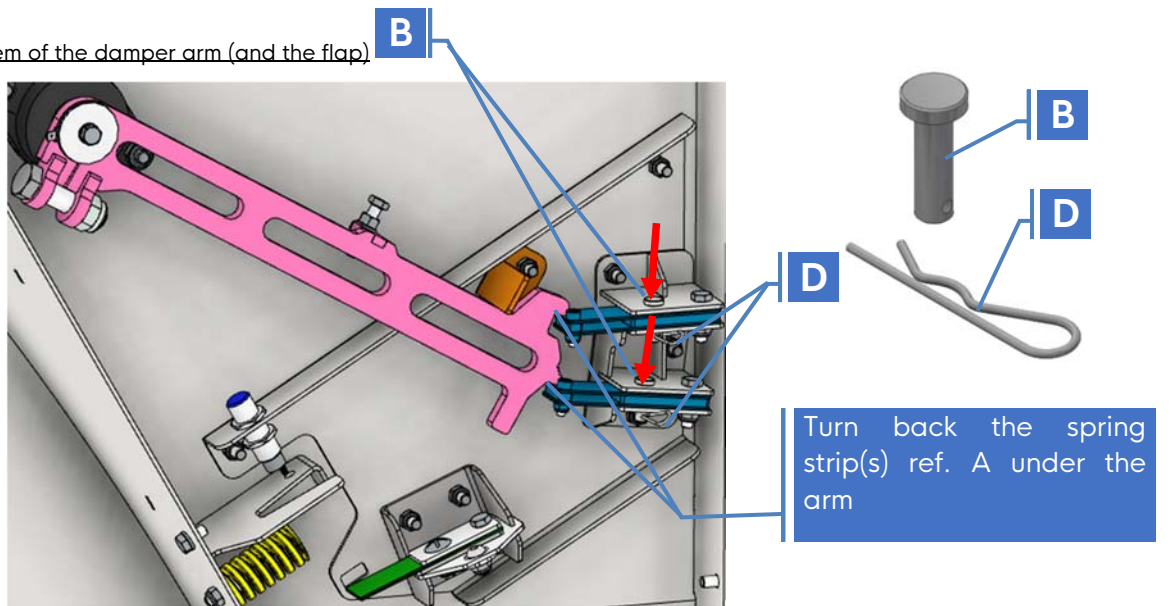

i In function of the BADA-VEX size, 3 models of flap kept open system exist. Number and design of spring strips are defined in this table (Tab-2):

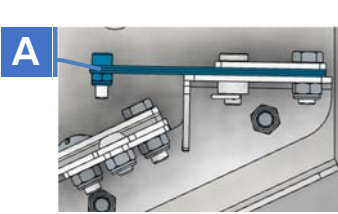
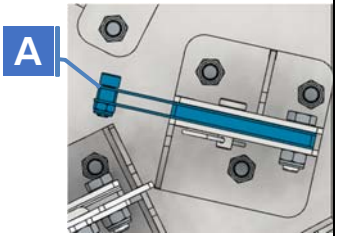
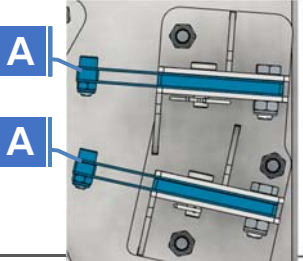
BADA-VEX range	Ø160 to Ø350 Ø6" to Ø14"	Ø400 to Ø450 Ø16" to Ø18"	Ø500 to Ø800 Ø20" to Ø32"
Version rep. A	Flexible	Rigid	Rigid
Qty rep. A	x1	x1	x2
Drawing			

6.4.3. Flap position indicator, when it's opened :

Totally open position is visible from outside via angular indicator ref. G (picture 9) independently of the running mode: flap kept open position from mechanic system or floating flap. When the flap is open, the indicator ref. G is on the top of the green part.

Picture 9

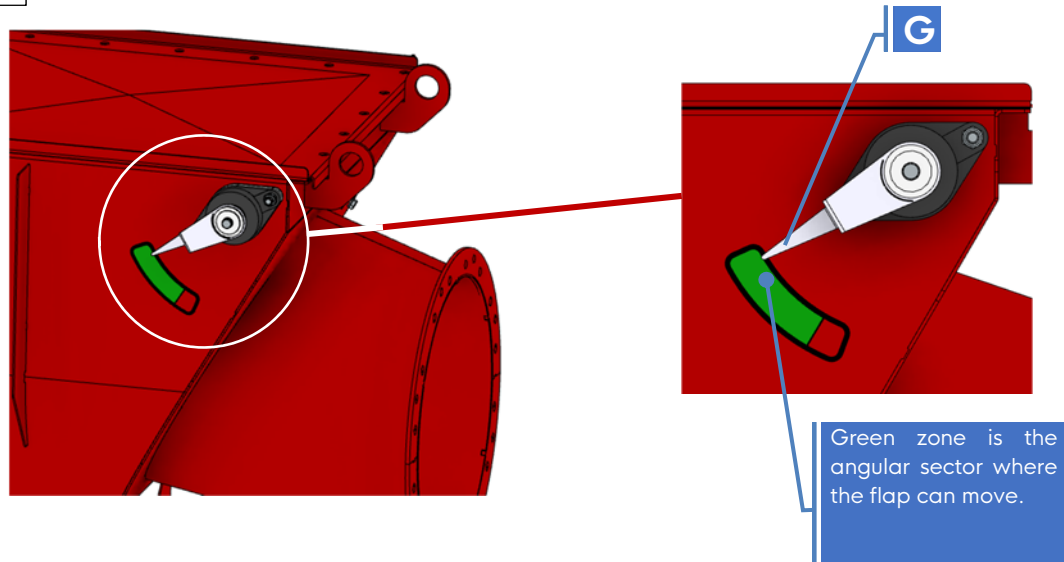

6.4.4. Flap position in idle position (only for floating flap mode) :

In floating flap mode the BADA-VEX flap is simply opened by airflow generated by the fan. When the fan is stopped, the flap drops down and the outside arm rests against the locking spring strip ref. H but unlocked by bottom spring(s) ref. I (picture 10).

Picture 10

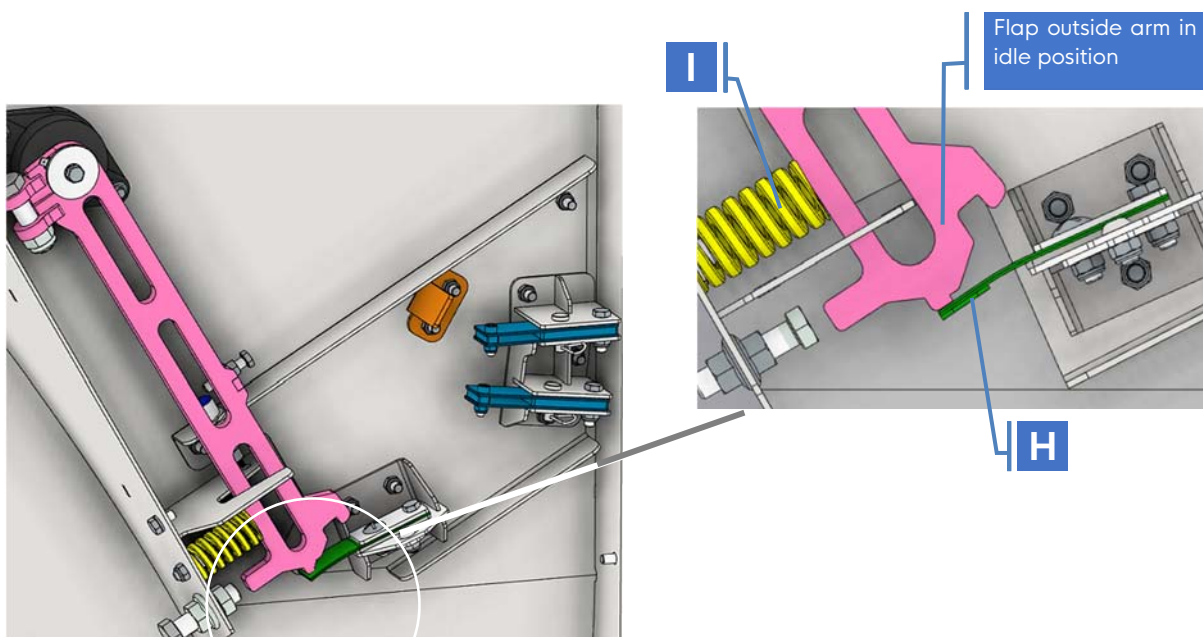

6.4.5. Flap indicator in waiting position :

Flap position in waiting is visible from outside by the indicator ref. G placed in limit of green and red zones. (Picture 11).

Picture 11

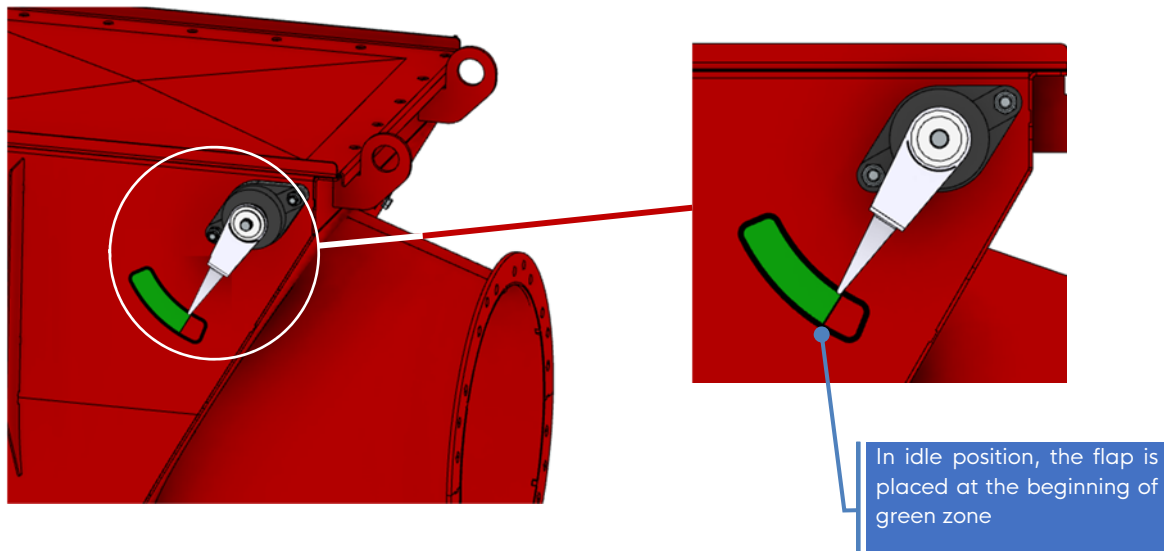

6.4.6. Flap locked in closed position :

The flap can be closed by explosion overpressure or by air flow > 35 m/s in case of BADA-VEX installed on clean air pipe, position **D** (picture 2). In this case, at the end of the fall, the outside arm pushes the spring(s) ref. I until the stop part ref. J, so the locked spring strip ref. H comes and lock the outside arm of BADA-VEX ref. K (picture 12).

- i** To unlock the flap, you have to press on the spring ref. I with the outside arm. So, you can push down on the locked spring strip ref. H in order to release the moving part.

Picture 12

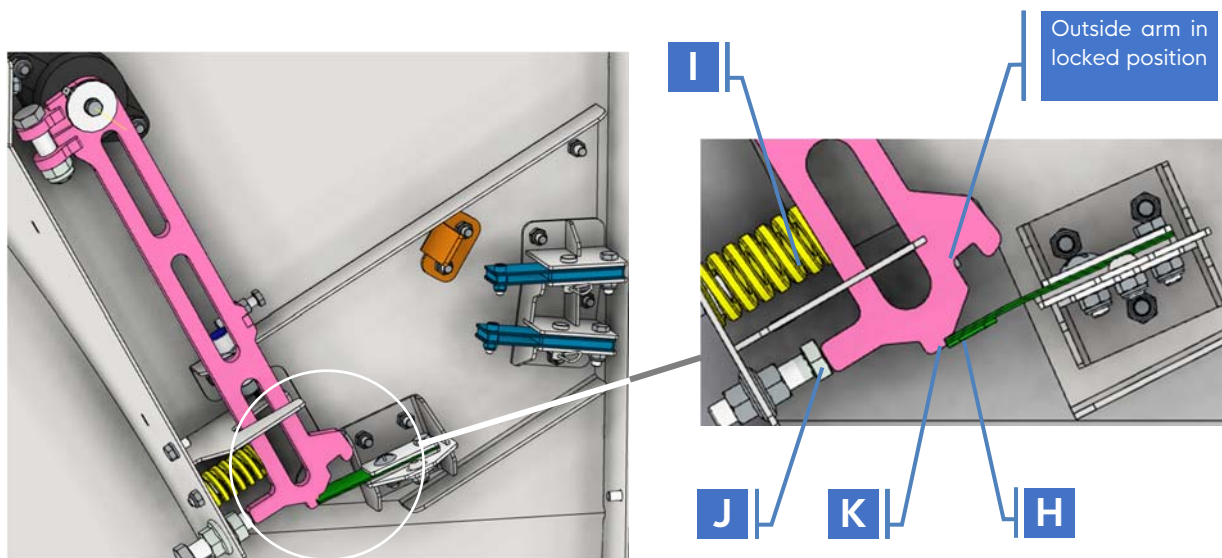

6.4.7. Indicator position with flap locked closed :

Flap position when it's closed locked (flame is stopped) is visible from outside by the indicator ref. G placed in the red zone (picture 13).

Picture 13

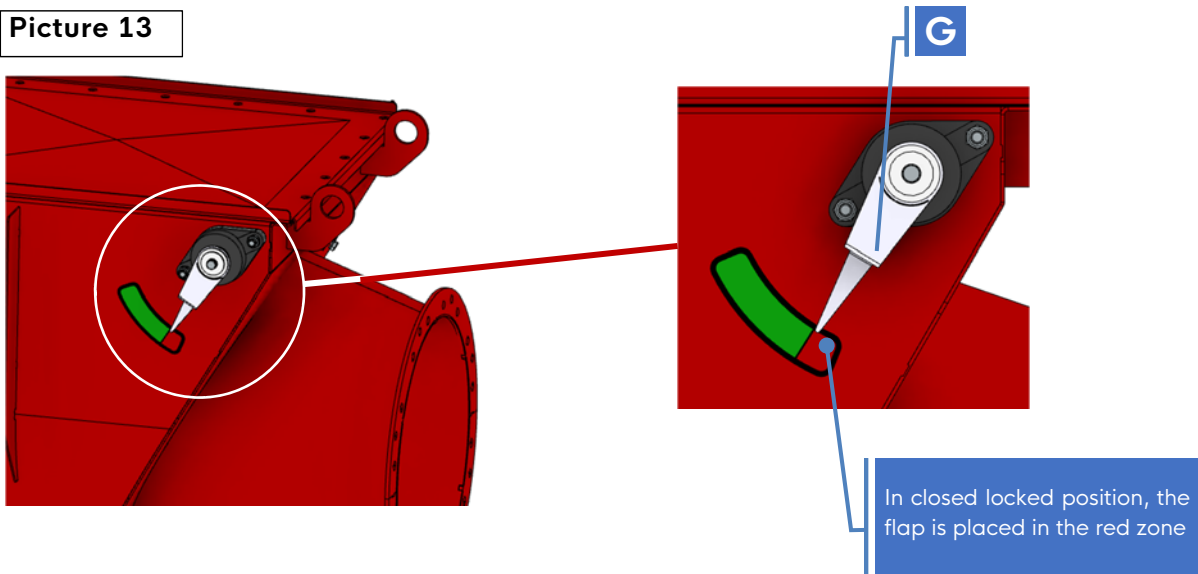

7. Installing the BADA-VEX



Verification required before starting the installation :

The installer has to check before starting the installation that the delivered material hasn't suffered any distortion.

BADA-VEX installation must be realized by qualified staff, especially regarding safety rules for workers when they can be in ATEX risk zone following European regulation n°1999/92/CE.

Upstream and downstream ducting must match the BADA-VEX pressure resistance (2 Bar).

7.1. Rules to install the BADA-VEX :

1. Always use lifting eyes ref. L when handling the BADA-VEX (picture 19).
2. Respect the installation distances Lmin, Lmax and also volumes Vmin according to the BADA-VEX size (pictures 16, 17, 18 and see TAB-1).
3. Attach the BADA-VEX on a support bracket to avoid that the pipes support the device's weight.
4. To put back the access door ref. P, you must tighten the M10 bolts with torque 20 Nm to avoid leakage (Picture 19).
5. Place gaskets between the BADA-VEX and the pipe flanges on either side.
6. Respect the tightening torque according to the bolt size of fixing flange (TAB-3).

Screw class \geq 6.8	Tightening torque
M6	5 Nm
M8	10 Nm
M10	20 Nm

7. Select the BADA-VEX working mode (Floating OR 'Locked Open' before installation).



NOTE : BADA-VEX is delivered with the flap in the 'Locked OPEN' position.

8. Respect the installation tolerances for HORIZONTAL and VERTICAL positioning (picture 14).

Picture 14

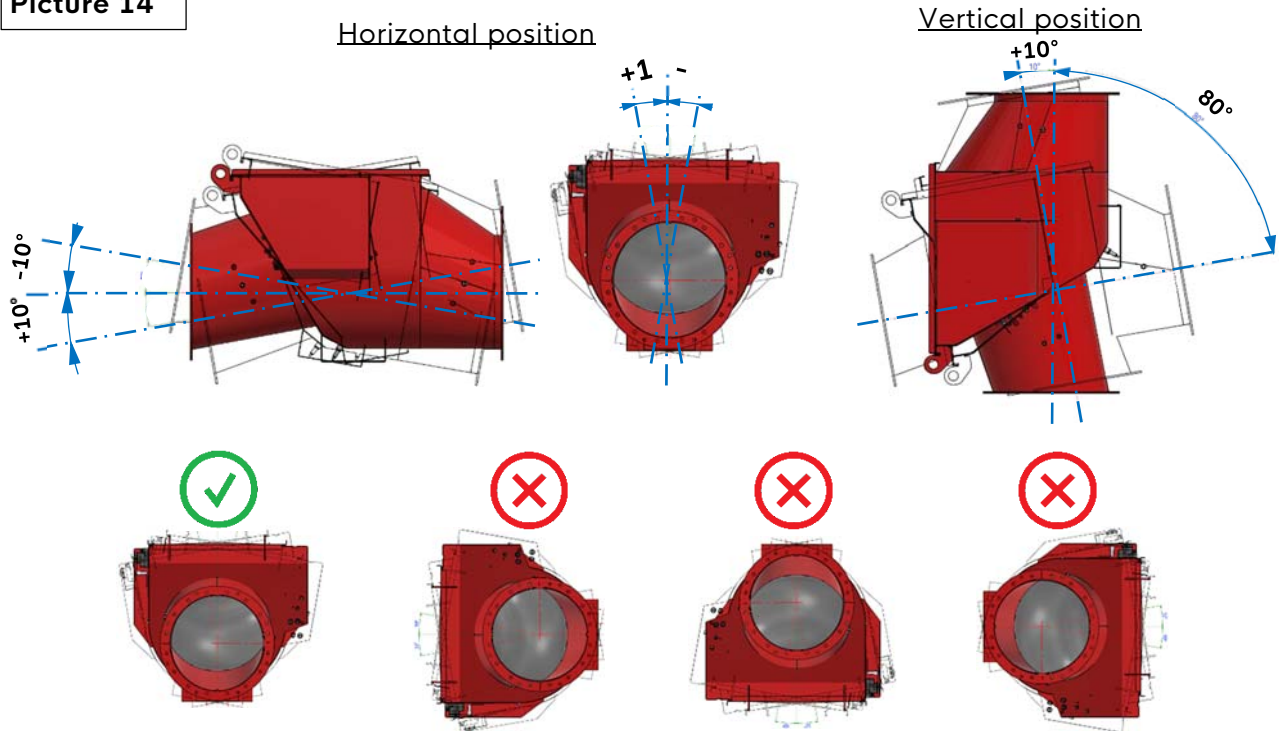

9. Allowed Orientation of BADA-VEX for horizontal and vertical installations (picture 15).

- The positions A and B according to BADA-VEX installations in horizontal position $\pm 10^\circ$.
- The positions C, D, E, F, G and H are according if the BADA-VEX is installed in angled or vertical positions (greater than $\pm 10^\circ$).

Figure 15

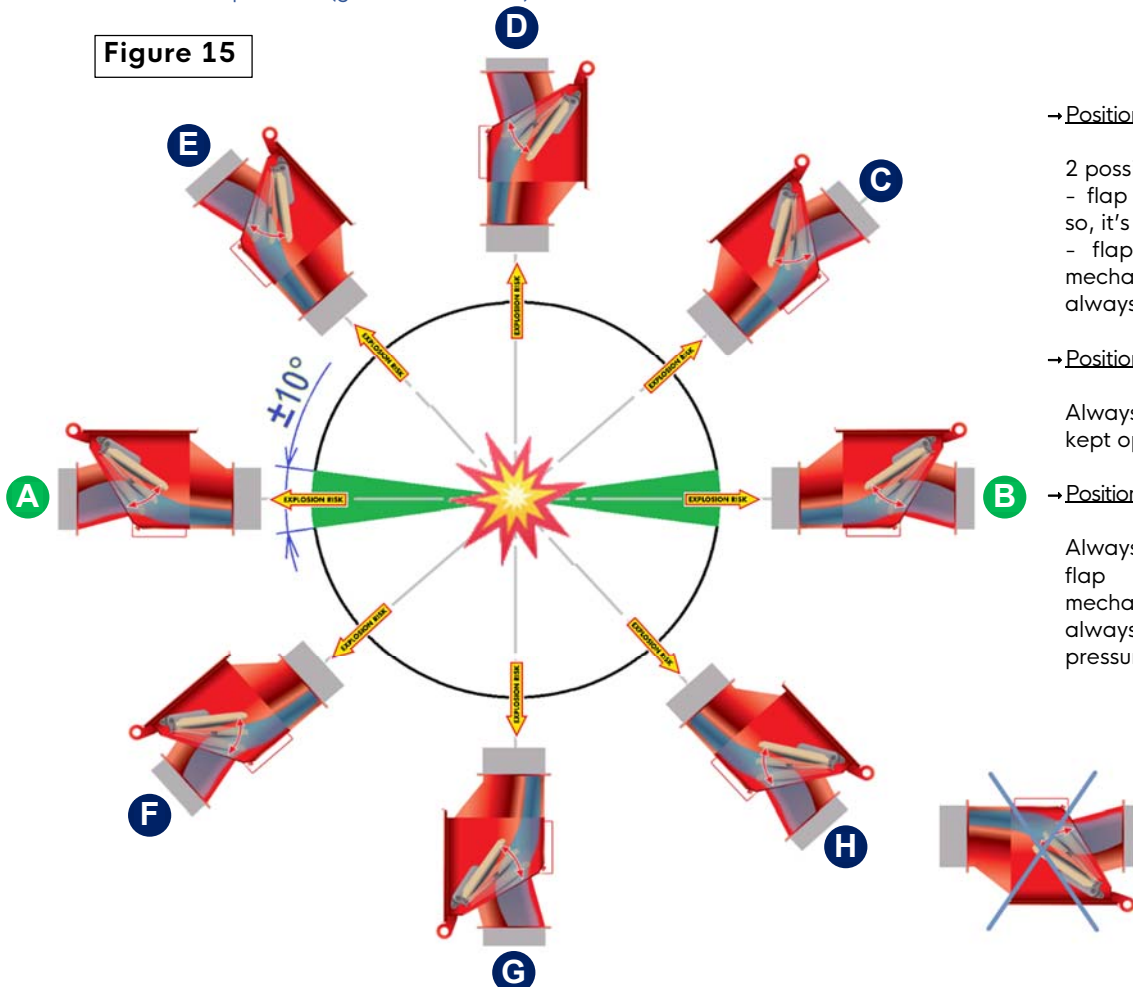

→ Position **A** to **E** & **B** to **C**

- 2 possibilities to work:
- flap in floating position so, it's open by airflow.
 - flap is kept open by mechanic system, so it's always open.

→ Position **C** to **D** & **E** to **D**

Always work with flap kept open by gravity.

→ Position **A** to **G** & **B** to **G**

Always need to work with flap kept open by mechanic system, so it's always open (if not pressure drop is too high).

10. Allowed installation distances from isolated vessel to BADA-VEX :

- Multiple bends are permitted (no quantity limit) in any position, upstream or downstream of the BADA-VEX. The system is functional with bend on the pipe in upstream or downstream of BADA-VEX. Lmin and Lmax installation distances must be observed (see TAB1).
- Lmax is 17 m, it includes all pipe elements (especially the bends) and it's measured on the center of the ducting.

Lmin : Min distance in floating flap mode on straight horizontal pipe ($\pm 10^\circ$), without bend (picture 17, see TAB 1).

Lmin+2m : Min distance between isolated vessel and BADA-VEX in at least one of following cases :

- Flap in Locked Open mode (picture 18, see TAB 1).
- Pipe with bend between isolated vessel and BADA-VEX, flap in horizontal position $\pm 10^\circ$ (see picture 18).

Pipe with elbow between isolated vessel and BADA-VEX, flap in vertical position (over 10°), observe following rules (pictures 16, TAB 1) :

- 1 * Min installing distance = Lmin+2m, if vertical pipe from bend to BADA-VEX $> 5 \times \varnothing$ pipe,
Or
- 2 * Min installing distance = Lmin + 2m + $5 \times \varnothing$, if vertical pipe from bend to BADA-VEX = $5 \times \varnothing$ pipe,
- 3 * Installation of BADA-VEX in vertical position must be done with vertical pipe of min $5 \times \varnothing$ pipe between bend and BADA-VEX.

Picture 16

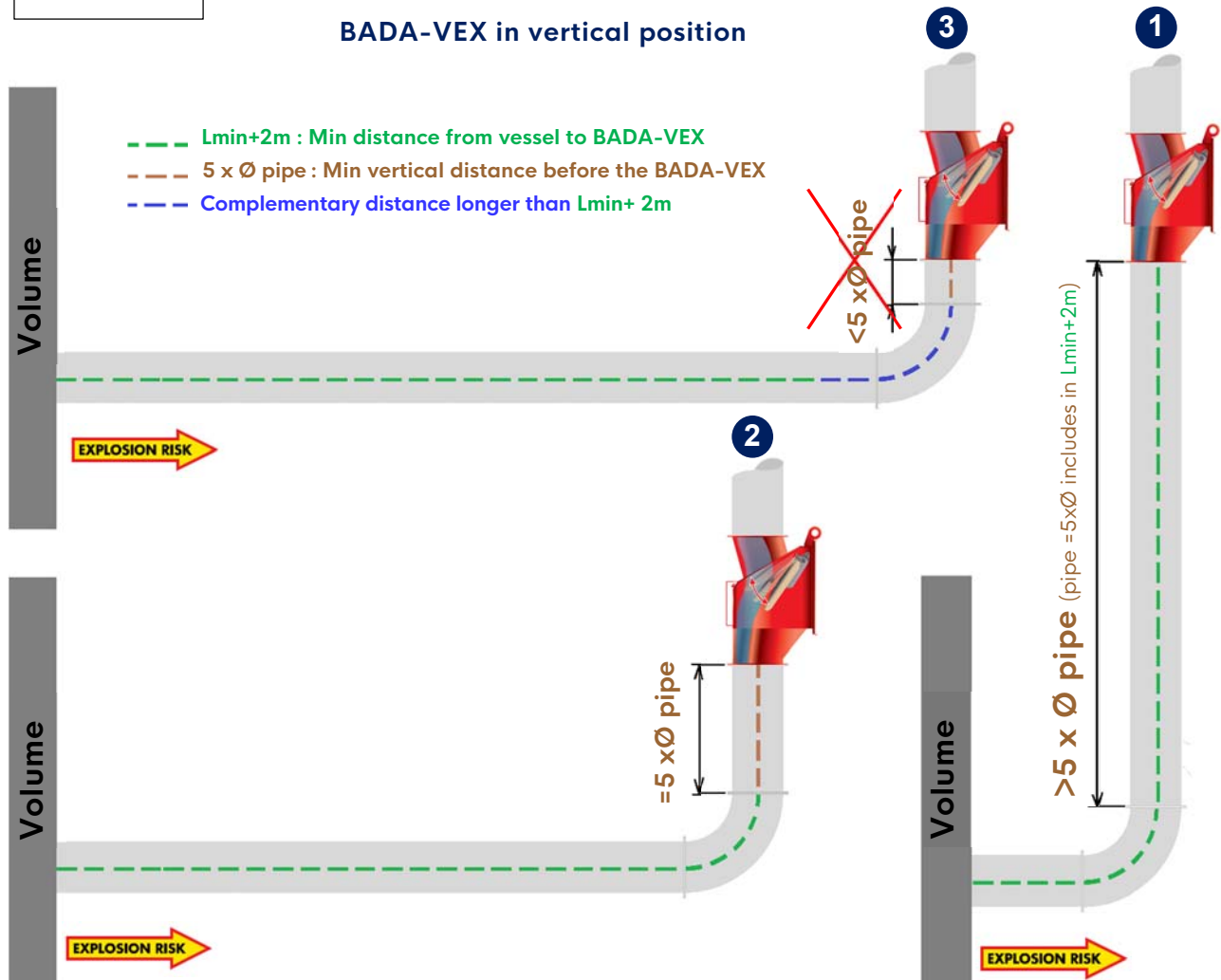

11. Reminder of installation conditions of BADA-VEX in horizontal position :

Lmin : In floating flap working, on straight horizontal pipe, without bend (picture 17, see TAB 1).

Lmin + 2m : Min distance between isolated vessel and BADA-VEX in at least one of following cases :

- Flap kept open by its spring system (pictures 17, 18, see TAB 1).
- Pipe with bend between isolated vessel and BADA-VEX, flap in horizontal position $\pm 10^\circ$ (see picture 18).

Picture 17

BADA-VEX in horizontal position, straight ducting

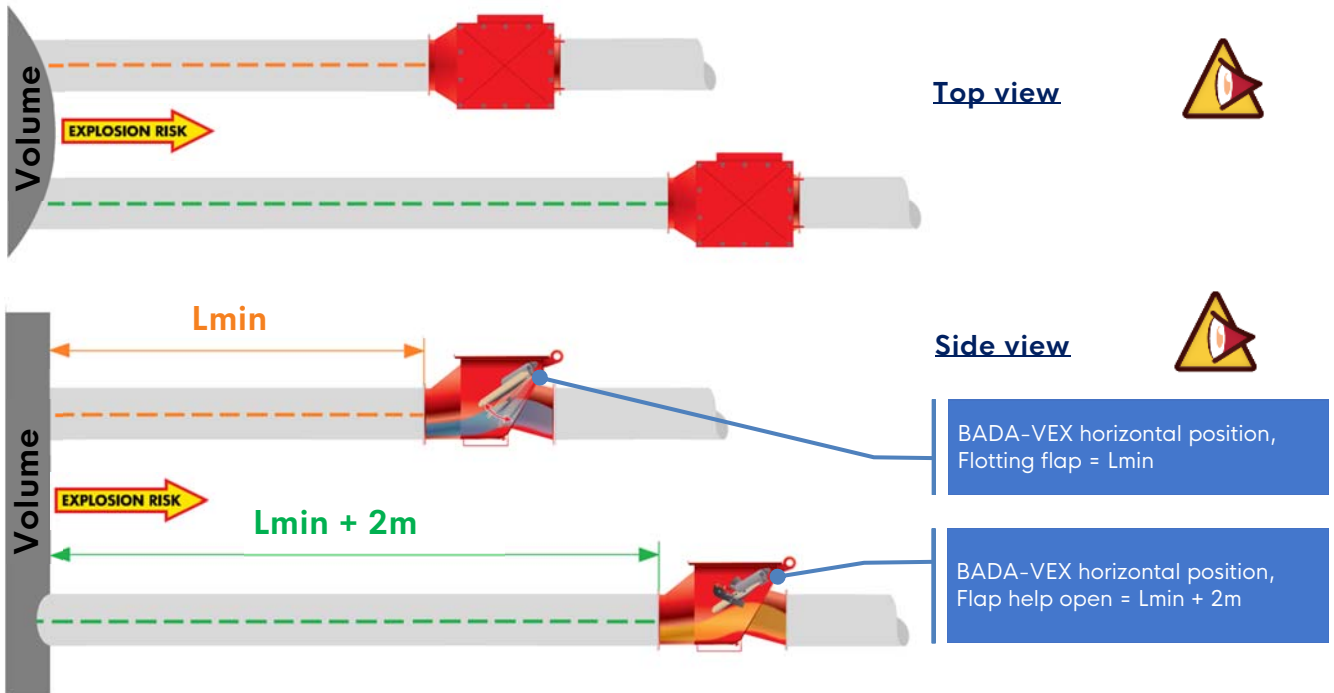

Picture 18

BADA-VEX in horizontal position, ducting with bends

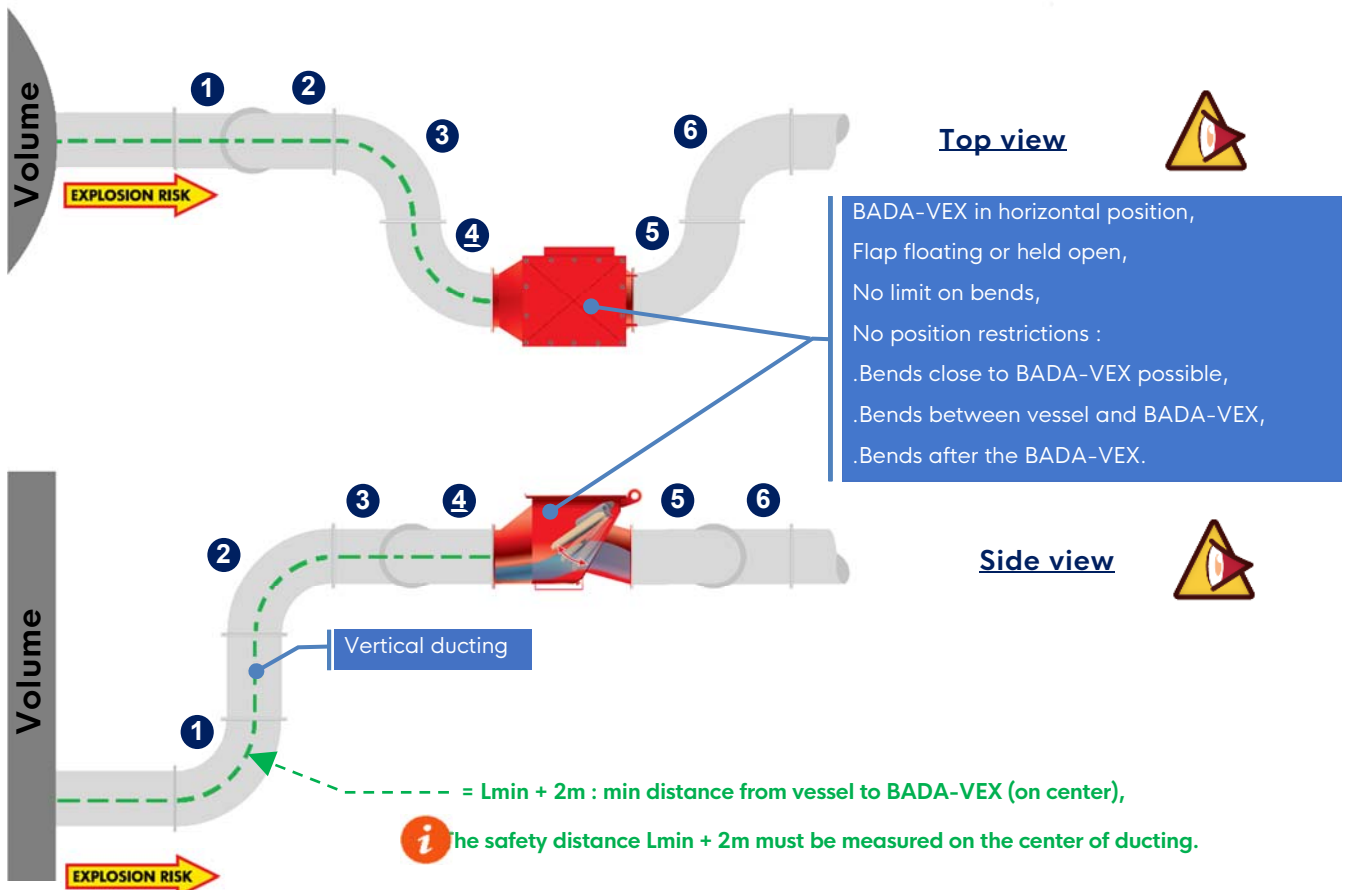

12. The inspection door is fixed during manufactory, after each maintenance operation, be sure to tighten all M10 bolts @ 20 Nm.

Picture 19

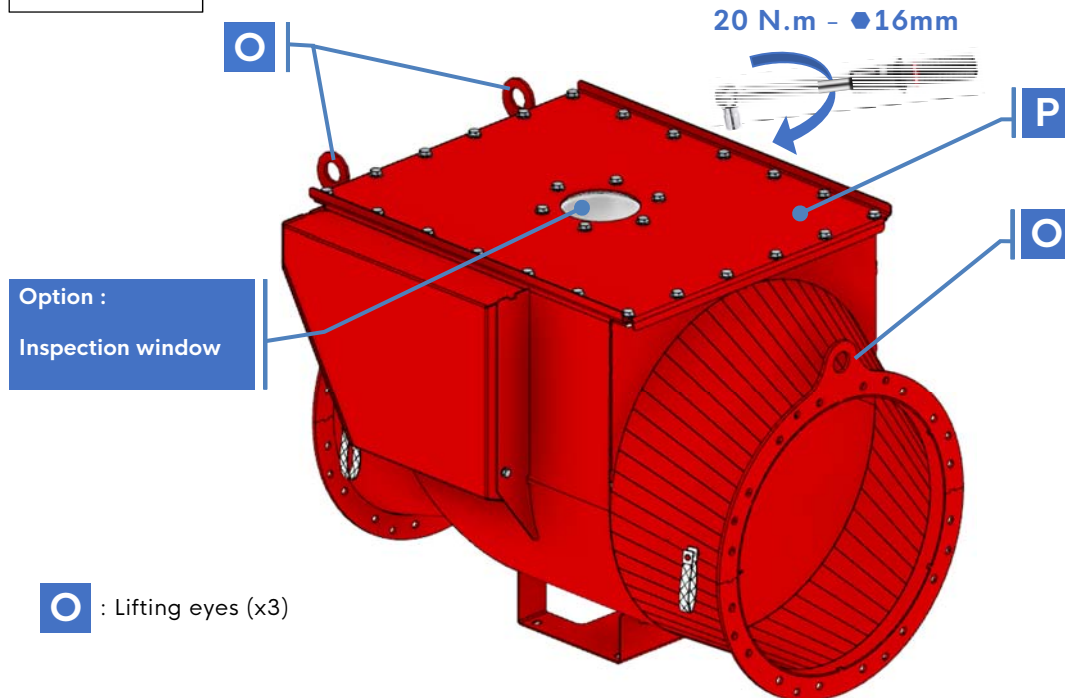

13. Connect both earthing straps ref. M from the BADA-VEX to the pipes on either side, upstream and downstream (Picture 20). Before starting to use the BADA-VEX, check electric continuity and that the earthing connection is efficient.

Picture 20

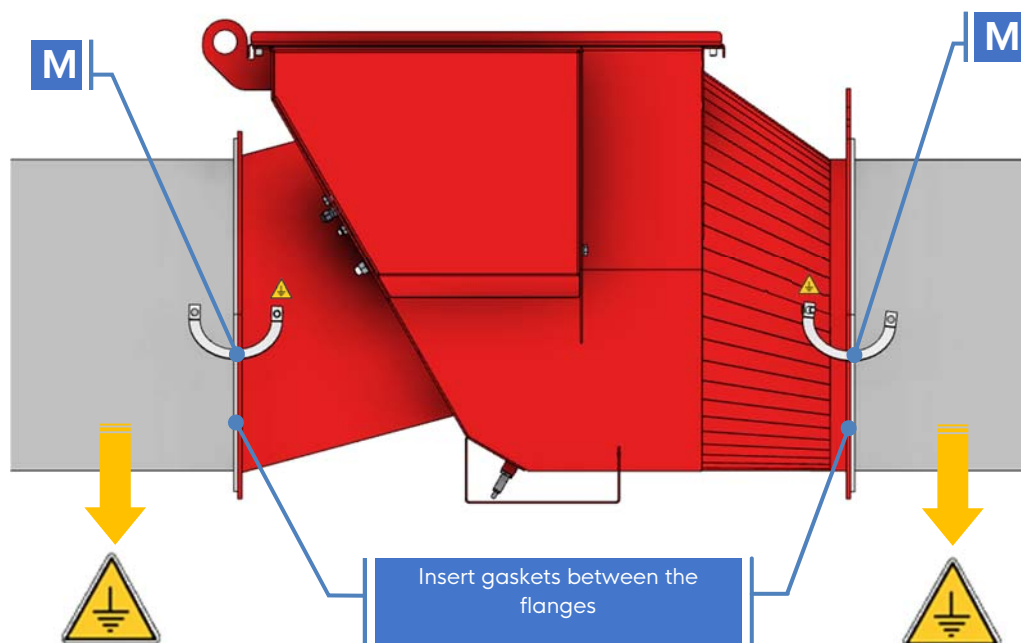

8. Overall dimensions (The list of models is not exhaustive)

The BADA-VEX is conceived on seven main body bases. The main bodies are indicated with an "x" in the tables TAB-4 and TAB-5, they are used for one or two other connected pipe diameter sizes.

The possible pipe diameter sizes are indicated in measure unit : metric (TAB-4) or imperial (TAB-5).

The BADA-VEX model is indicated according to the pipe size, example DN200.

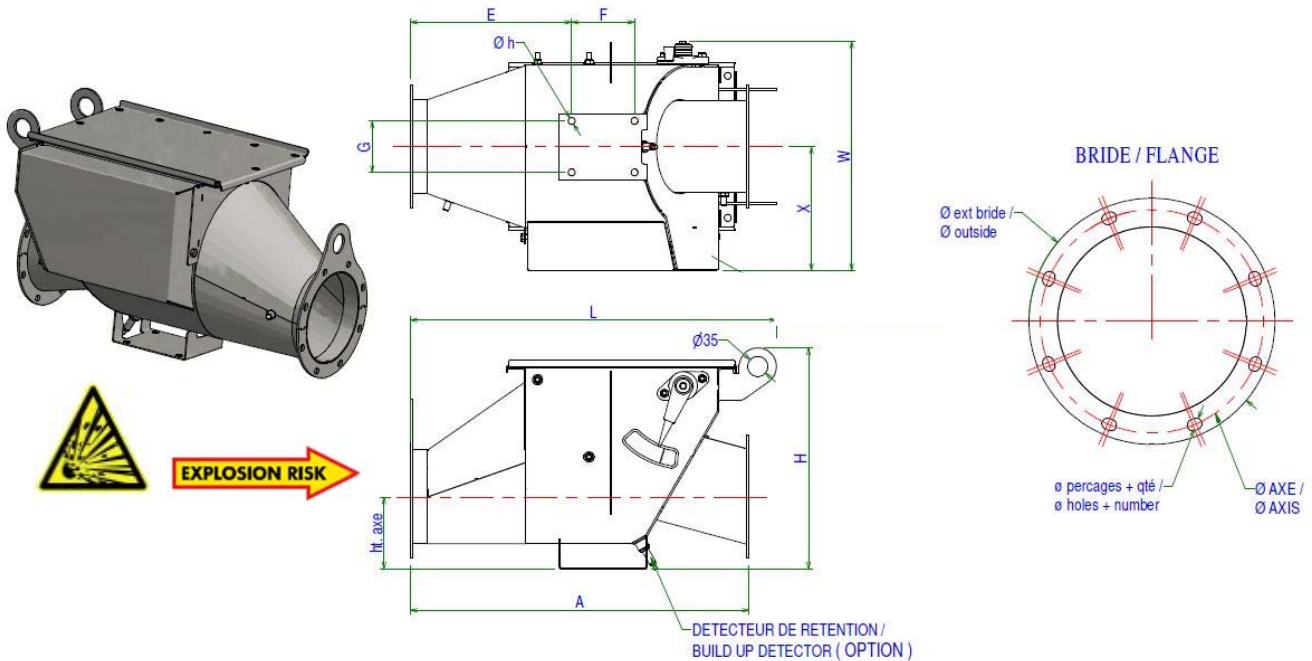

8.1. BADA-VEX range in metric « DN » (TAB-4)

Ø BADA-VEX		Overall dimensions				Flange				Duct		Mounting support				Weight Kg
Ducting DN	Body	L	H	W	X	Ø ext.	Ø axis	qty.	Ø holes	A	Ht axis	E	F	G	Ø h holes	
		mm	mm	mm	mm	mm	mm		mm	mm	mm	mm	mm	mm	mm	
160	x	640	386	400	216	215	195	8	10	591	126	282	110	90	12	21
180		612				235	215	8	10	531	136	254				
200		857	466	490	261	255	235	12	10	857	138	325	160	140	12	35
250	x	717				305	285	12	10	671	163	253				33
300		966	575	590	311	355	336	12	10	966	197	373	160	160	12	44
350	x	817				415	389	12	12	776	222	302				50
400		1088	705	740	385	465	439	16	12	1089	249	431	180	260	12	81
450	x	945				515	489	16	12	893	274	359				77
500		1197	815	840	434	565	540	16	12	1 199	309	441	200	300	12	106
550	x	1045				615	590	16	12	996	334	369				104
600		1549	1038	992	508	665	640	16	12	1549	366	588	200	400	12	150
650		1363				715	690	24	12	1364	391	517				150
700	x	1207				785	750	24	12	1155	416	446				150
750		1751	1213	1200	602	835	800	24	12	1752	443	514	400	500	12	285
800	x	1563				885	850	24	12	1564	468	442				285

8.2. BADA-VEX range in imperial « DN » (TAB-5)

Ø BADA-VEX		Overall dimensions				Flange						Duct		Mounting support				Weight Kg	
Ducting DN	Body	L	H	W	X	Ø ext.	Ø axis	qty.	Ø holes		A	Ht axis	E	F	G	Ø h holes			
		mm	mm	mm	mm	mm	mm		mm	inch	mm	inch	mm	mm	mm	mm	mm	mm	
6"	x	649	386	400	216	209	185,7	7- 5/16	6	7,1	9/32	628	120	291	110	90	12	21	
7"		616				238	215,9	8-1/2	6	9,5	3/8	559	133					258	20
8"		857	466	490	261	263	242,9	9- 9/16	6	9,5	3/8	857	138	325	160	140	12	35	
10"	x	717				327	300	11- 13/16	6	11,1	7/16	670	163					253	33
12"		966	575	590	311	384	355,6	14	8	11,1	7/16	965	197	373	160	160	12	50	
14"	x	817				435	406,4	16	8	11,1	7/16	776	222					302	50
16"		1089	705	740	385	486	457,2	18	8	11,1	7/16	1089	249	431	180	260	12	81	
18"	x	945				536	508	20	8	11,1	7/16	893	274					359	77
20"		1199	815	840	434	587	552,5	21- 3/4	12	11,1	7/16	1199	309	441	200	300	12	110	
22"	x	1039				638	603,3	23- 3/4	12	11,1	7/16	981	336					364	110
24"		1541	1038	992	508	689	657,2	25- 7/8	12	11,1	7/16	1538	368	582	200	400	12	178	
26"		1353				766	720,7	28- 3/8	16	11,1	7/16	1353	393					512	170
28"	x	1200				816	771,5	30- 3/8	16	11,1	7/16	1138	419					438	170
30"		1739	1213	1200	602	867	822,3	32- 3/8	16	11,1	7/16	1739	444	508	400	500	12	285	
32"	x	1548				918	873,1	34- 3/8	16	11,1	7/16	1545	470					435	285

9. Flap locking sensor (in closed position)

The BADA-VEX is equipped with an inductive sensor (external) which detects when the flap is locked in closed position (picture 21). It sends a signal to stop the installation when the sensor detects the target screw (ref. Q) in closed position (explosion is isolated).



The BADA-VEX is equipped in standard execution with a non-ATEX detector version. Optionally, ATEX sensors are available for ATEX II2 D (zone 21).

Sensors have different sizes according to BADA-VEX size :

- Inductive sensor Ø12 for BADA-VEX DN≤350 (DN≤14")
- Inductive sensor Ø18 For BADA-VEX DN≥400 (DN≥16")

We advise combining the position sensor to a sound alarm, light alarm or process PLC to have information regarding the locking closed position of flap following an explosion accident or unusual running.



The sensor works in positive safety running, (NC switch) when the flap is not locked in closed position.



The sensor installations is set in the factory. In case of its replacement, you have to simulate the locked in closed position of outside arm in order to set the target screw (ref. Q) in front of the sensor in detection condition. You will have to adjust the length of the target screw (ref. Q) until the sensor status changes (switches off), then tighten the counter-nut to lock the setting.

Picture 21

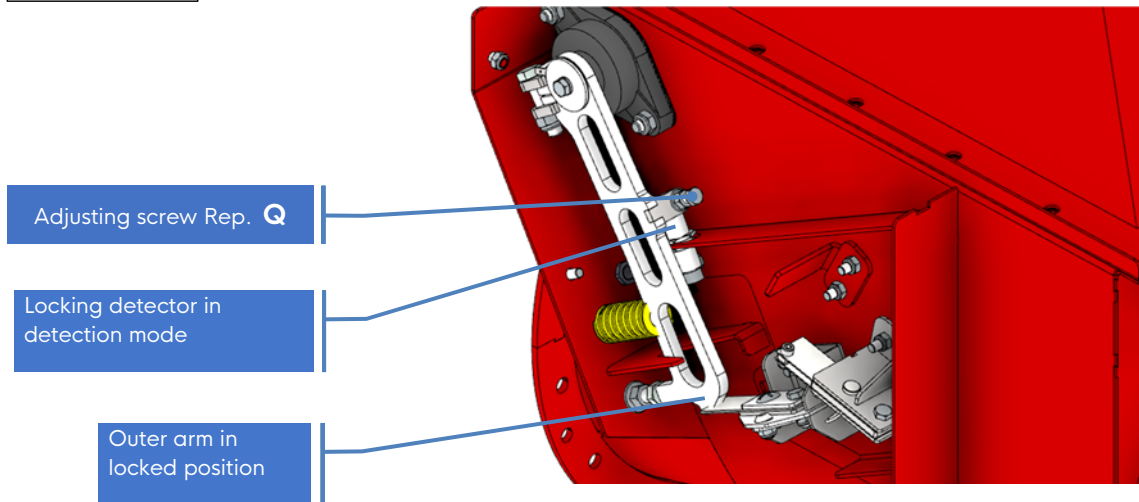

9.1. Inductive sensor Ø12 non-ATEX zone (DN≤350 - DN≤14") :

Supply voltage :	Ue 12...48 V DC
Switching current max :	Ie 200 mA
Degree of protection :	IP68
Output function :	NC
Output function kind :	PNP
Operation temperature :	-25°C<Ta<+70°C
Cable :	2m - 3 wires of 0.34 mm²
Indication LED :	Output indication 1 yellow LED



i Electric connecting sketch : +BN, -BU, Charge BK/BU

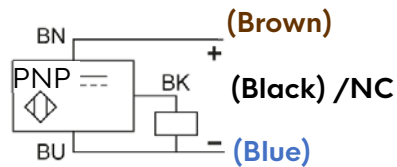

9.2. Optional : inductive sensor Ø12 for ATEX zone - Ex II 2 D (DN≤350 - DN≤14") :

Supply voltage :	Ue 12...48 V DC
Switching current max :	Ie 200 mA
Degree of protection :	IP68
Output function :	NC
Output function kind :	PNP
Operation temperature :	-20°C<Ta<+60°C
Cable :	10m - 3 wires of 0.34 mm²
Indication LED :	Output indication 1 yellow LED
ATEX marking :	II 2 D_Ex tb IIIC T90°C Db
ATEX/IECEX Certificate :	INERIS 04ATEX0022 / INE 17.0006



i Electric connecting sketch : +BN, -BU, Charge BK/BU

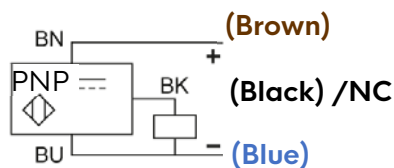

9.3. Inductive sensor Ø18 non-ATEX zone (DN≥400 - DN≥16") :

Supply voltage :	Ue 12...24 V DC
Switching current max :	Ie 200 mA
Degree of protection :	IP67
Output function :	NC
Output function kind :	PNP
Operation temperature :	-25°C<Ta<+70°C
Cable :	2m - 3 wires of 0.14 mm ²
Indication LED :	Output indication 1 yellow LED

i Electric connecting sketch : +BN, -BU, Charge BK/BU

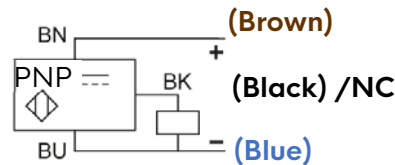

9.4. Optional : inductive sensor Ø18 for ATEX zone - II 2 D (DN≥400 - DN≥16") :

Supply voltage :	Ue 12...48 V DC
Switching current max :	Ie 200 mA
Degree of protection :	IP68
Output function :	NC
Output function kind :	PNP
Operation temperature :	-20°C<Ta<+60°C
Cable :	10m - 3 wires of 0.34 mm ²
Indication LED :	Output indication 1 yellow LED
ATEX marking :	II 2 D_Ex tb IIIC T90°C Db
ATEX/IECEx Certificate :	INERIS 04ATEX0022 / INE 17.0006

i Electric connecting sketch : +BN, -BU, Charge BK/BU

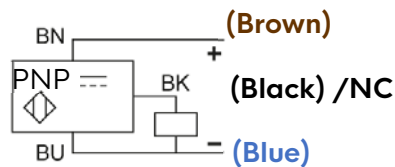

10. Dust build-up sensor

BADA-VEX can optionally be equipped with a capacitive sensor and/or inspection window which allows to check accumulation of dust in the isolated zone of flap, for BADA-VEX installed in horizontal or vertical position.

This option provides additional indication of dust build-up which can prevent the efficient closure of the flap during an explosion occurrence (pictures 22 and 23).

In standard version, the BADA-VEX is equipped with 2 brass caps ref. R which are tightened at 20 Nm. These caps are designed to close the threaded holes when the capacitive sensor is not in place (picture 22).

Picture 22

Placing the capacitive sensor on a BADA-VEX installed in position :

HORIZONTAL

Option :

Inspection window

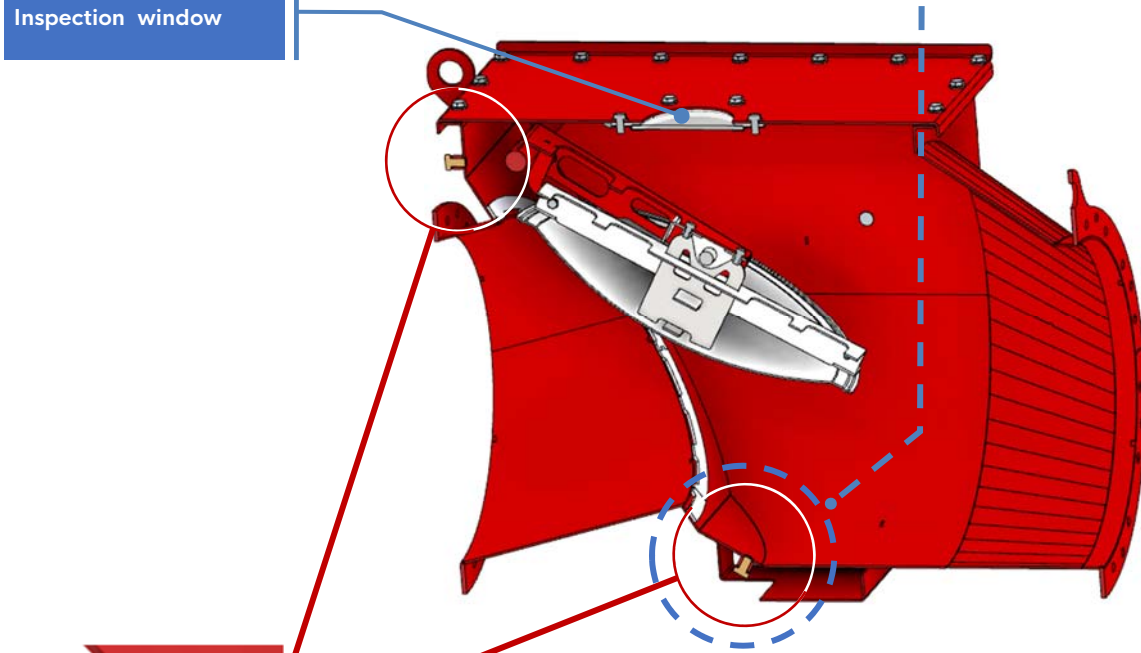

Placing the capacitive sensor on a BADA-VEX installed in position :

VERTICAL

R

Option :

Inspection window

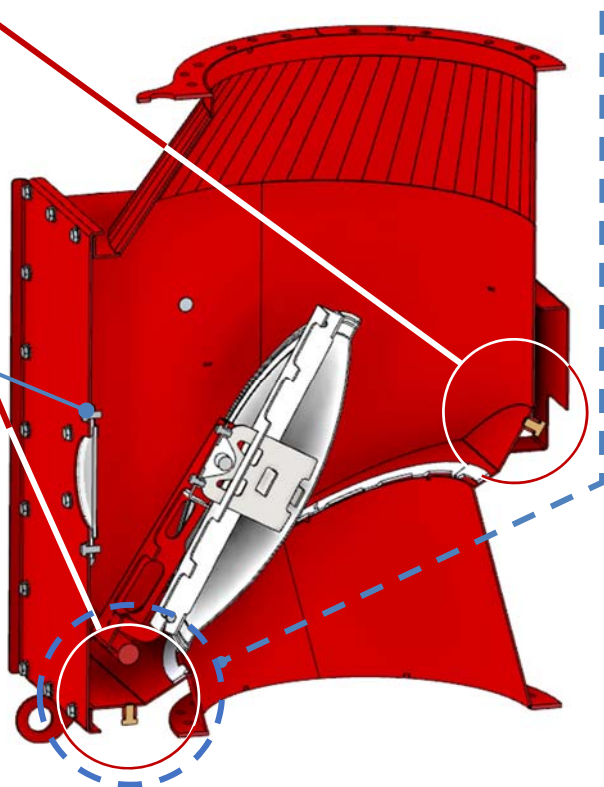
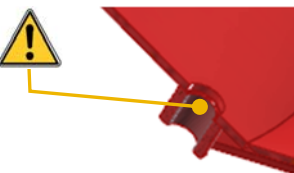

Never use BADA-VEX if the threaded holes are not obstructed either by the brass cap ref. R or by the capacitive sensor $\varnothing 12$. Never use BADA-VEX if the inspection window is damaged or missing (if this option is present).

Picture 23

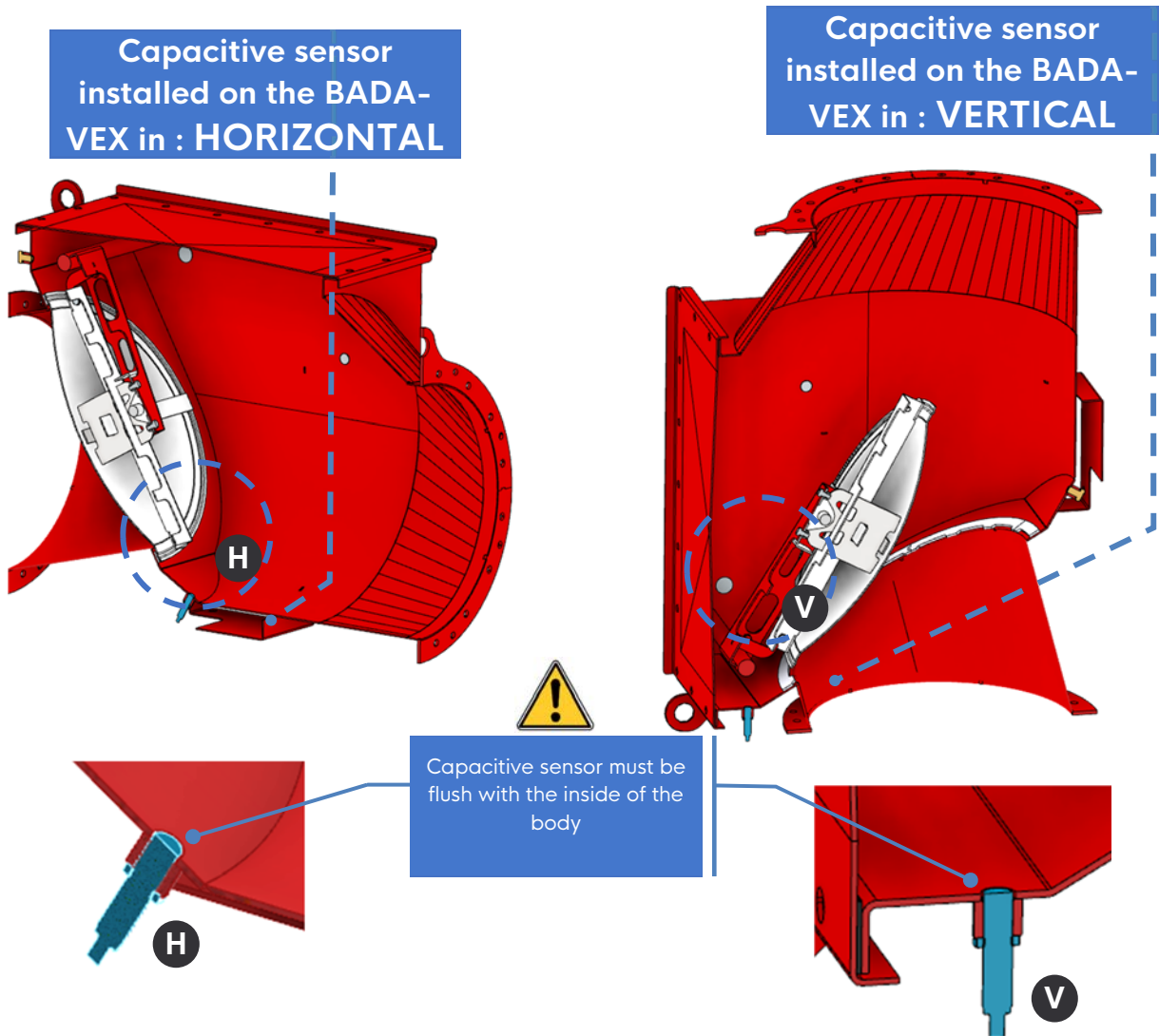

10.1. Capacitive sensor Ø12 for ATEX zone - Ex II 1 D :

Output function kind :	NAMUR DIN 60947-5-6
Supply voltage :	UB 5 - 15 V DC, $U_i = 15$ V DC
Switching current out of detection :	$\leq 1,5$ mA
Switching current during detection :	$\geq 2,5$ mA
Degree of protection :	IP67
Indication LED :	Yellow
Operation temperature :	$-20^\circ\text{C} < T_a < +70^\circ\text{C}$
Cable :	2m - 2 wires of $0,14$ mm ²
ATEX marking :	II 1 D_Ex ia IIIC T101°C Da
ATEX/IECEX Certificate :	DMT 03 ATEX E 048 / BVS 07.0031



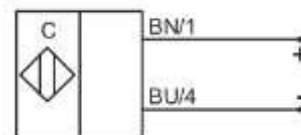

i Electric connecting sketch : +BN, -BU, Charge BK/BU



Namur sensors have to be used with switch amplifier approved for intrinsic mode according to EN 60079-11: 2012.

11. ATEX marking

ATEX marking is according to the requirement of ATEX European regulation 2014/34/UE.

 The marking  II D on the label indicate that the BADA-VEX is a protected device for dust explosive atmosphere.

11.1. Certification features :

- 0080 Notified body number of supervision, INERIS
- INERIS 23ATEX0012X Certificate number delivered by INERIS
- EN 16447 : 2014 European standard – Explosion isolation flaps
- EN 15089 : 2009 European standard – Explosion isolation systems

11.2. Scope of the standards present on product marking :

- **EN 16447** for the installation of the floating flap valve or kept open by the mechanical system which protects against the propagation of an explosion in the direction opposite to the flow (Loaded air).
- **EN 15089** for the installation of the flap-valve kept open by a mechanical system which protects against explosion propagation in the direction of flow (Clean air).

11.3. Marking example :

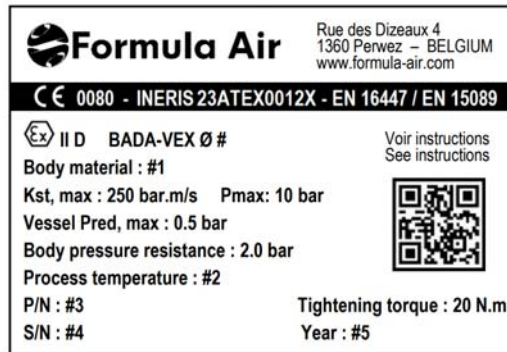

1)  II D	Protected device for ATEX dust types
2) BADA-VEX Ø250	Valve model and pipe connection size
3) Body material	Body raw material (example : painted steel)
4) Kst max	Max. explosion speed level of the dust (bar.m/s)
5) Pmax	Max. explosion pressure of the dust in a closed vessel (bar)
6) Vessel Pred,max	Max. explosion reduced pressure in the vessel (bar)
7) Body pressure resistance	Pressure resistance of the BADA-VEX body (bar)
8) Process temperature	Working temperature range (C°)
9) P/N	FORMULA AIR article code reference
10) S/N	Serial number of the device
11) Year	Production year of the device
12) 20 N.m	Bolt tightening torque of the access door

12. Aeraulic pressure loss

The pressure drop (ΔP) is different depending on whether the BADA-VEX is installed on the loaded air side (TAB-6) with a valve kept open or on the loaded air side (TAB-7) with a floating valve or on the filtered clean air side (TAB-8).

Loaded air : (TAB-6) (TAB-7)
 The total airflow velocity range is 15 m/s (3000 ft/min) to 45 m/s (9000 ft/min).
 The recommended airflow speed range is 20 m/s (4000 ft/min) to 30 m/s (6000 ft/min).

Clean air : (TAB-8)
 The values are available on the airflow range from 15 m/s (3000 ft/min) to 30 m/s (6000 ft/min).

12.1. Pressure loss graphs

Loaded air side: air + dust, Flap kept open (TAB-6) :

Loaded air side: air + dust, Floating flap (TAB-7) :

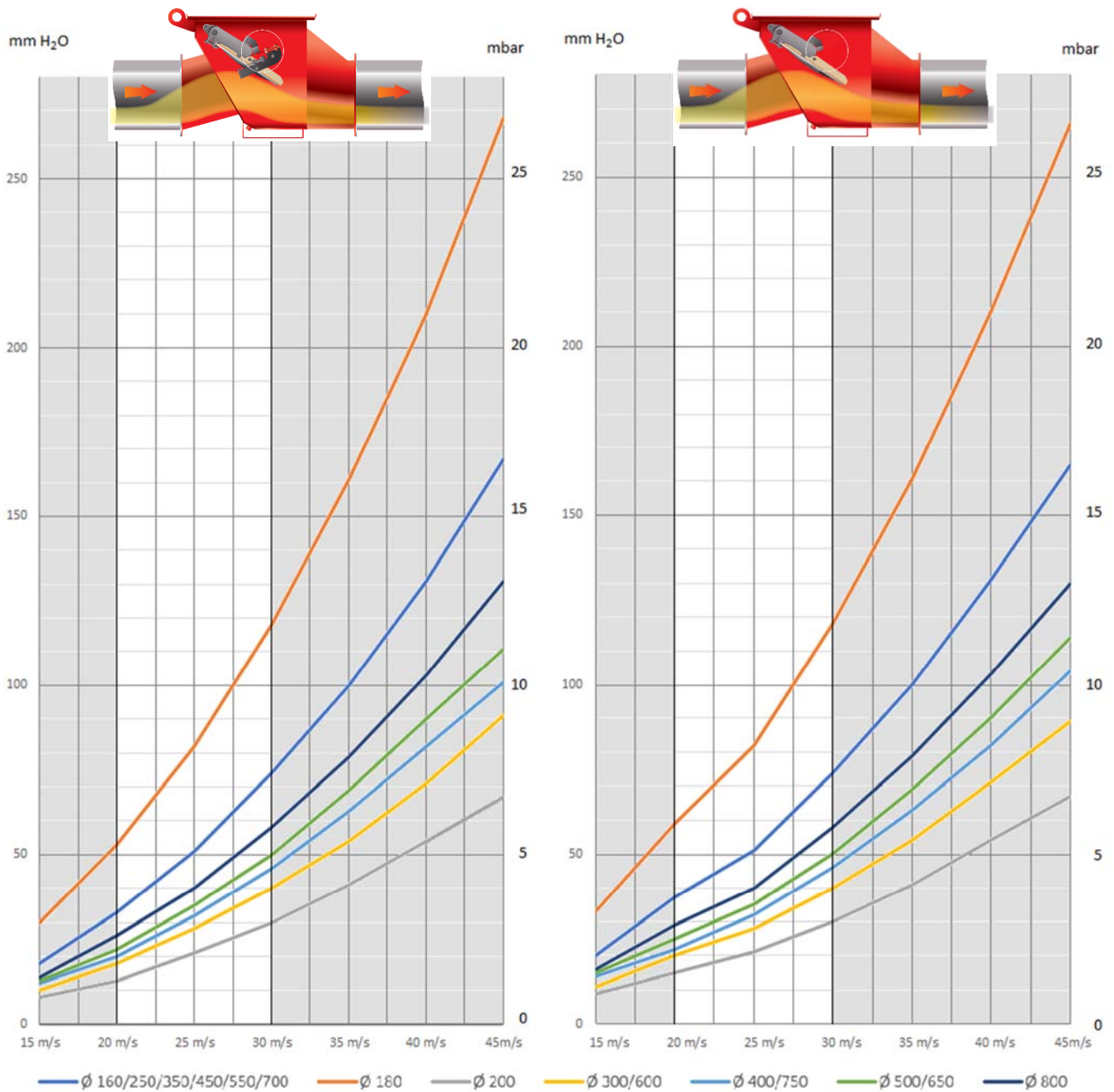

Clean air side, filtered (TAB-8)

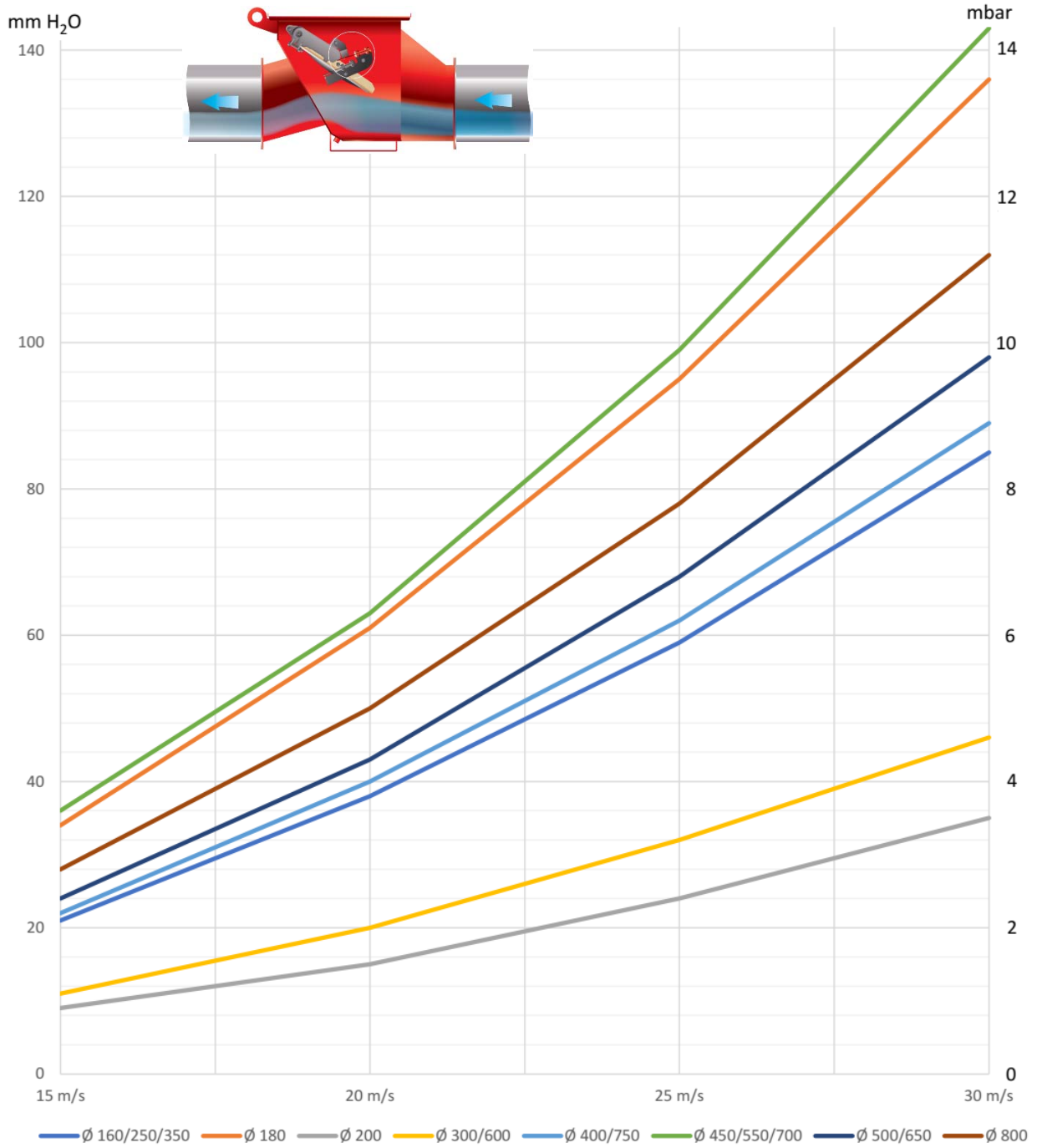

12.2. Pressure loss values (in mm H₂O /inch Wg) measured at 20 m/s (4000 ft/min) (TAB-8).

BADA-VEX DN	160 6"	180 7"	200 8"	250 10"	300 12"	350 14"	400 16"	450 18"	500 20"	550 22"	600 24"	650 26"	700 28"	750 30"	800 32"
Air + dust Flap held open	33	53	13	33	18	33	20	33	22	33	18	22	33	20	26
Air + dust Floating flap	37	59	15	37	20	37	22	37	25	37	20	25	37	22	29
Clean air Flap help open	38	61	15	38	20	38	40	63	43	63	20	43	63	40	50

13. Maintenance operations and periodic inspections

13.1. Standard requirements :

According to EN16447 and EN15089 regulations, specific periodic inspections have to be planned to ensure that the BADA-VEX maintains its efficient isolation function against explosion propagations at all times.

From these inspections, you must check that the BADA-VEX maintains its high safety level, for example from corrosive defect, abrasive effect, dust build up in the flap gasket zone, etc.

Periodic inspection frequency needs to be regular enough to avoid dangerous situations or degradation (cases of higher risk of bad BADA-VEX operation).

 To define the periodic inspection frequency, we advise to wait a short time between the first inspections when you start the BADA-VEX to clearly define the necessary time between inspection operations, following installation and BADA-VEX condition evolution. The time between 2 inspection operations cannot be more than 1 year. Adjust it following of the BADA-VEX status.

Only trained and entitled workers in maintenance procedures for ATEX equipment are authorized to carry out periodic inspections of the BADA-VEX. Periodic inspection results must be recorded in a register.



Before starting inspection or maintenance operations on the BADA-VEX, you must secure the zone, you especially have to check and be sure that the airflow is switch off and that it is impossible to inadvertently set it into operation.

13.2. Periodic inspection operations :

Start to take off the side safety cover and the top access door.

Then, take off the top stop piece ref. S of the external arm of the flap and turn the moving parts towards the top, outside of the BADA-VEX body (picture 24).

Picture 24

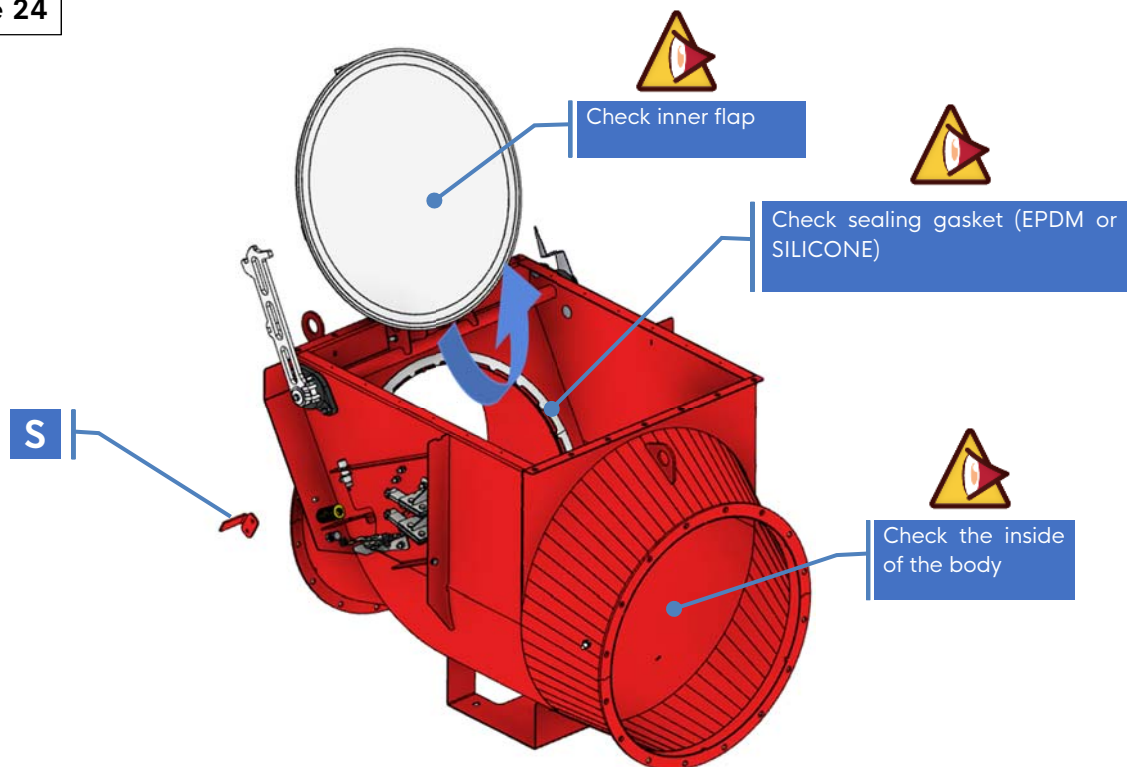

13.3. Check all following points (TAB-9):

Inspection	Checking zone	Observed defect	Maintenance
Dust build-up	Inside the body	Presence of a dust layer >1mm (0.04")	Clean the dirty zones
Abrasive effect	Flap	High abrasive damage \diamond	Replace the flap *
	Inside the body	High abrasive damage \diamond	Replace the BADA-VEX *
Airtightness	Flap gasket	Gasket distortion	Replace the gasket according to original material *
	Top access door gasket		
Corrosive effect	Inside and outside the BADA-VEX	High corrosive damage \diamond	Replace the BADA-VEX *
Chock	Inside and outside the BADA-VEX	High body distortion	Replace the BADA-VEX *
	Flap	Flap distortion	Replace the flap *
Functioning	Mobile parts	Abnormal stress on the shaft rotation	Replace the BADA-VEX *
Lock in closed position	Locking system	Locking spring strip missing	Return the device to Formula Air to do manufacture maintenance
		Damage on the locking system	
Earthing	Earthing strap fixing	Equipotential link interruption	Tighten the fixing points of the earthing straps
Pipe connection	Fixing bolts (pipe flanges)	Defect of bolt tightening	Check the bolt tightening according to advised torque, see TAB-3
Locking signal	Locking position sensor	The sensor don't switch off when the flap is locked in closed position	Set up the gap with target $\leq 2\text{mm}$
			Replace the sensor (same item) *
Bottom sleeve hole	Under the flap	Brass cap lack or capacitive dust build-up sensor missing	Put the capacitive sensor or the brass cap *

\diamond Wear over 15% of original thickness is considered as high level. Replace the defective device.

* Only replace the components by original BADA-VEX spares.



For all other maintenance operations, you have to send request to Formula Air technical staff.

After inspection and/or maintenance operation, all mobile components need to be placed back in the initial position (floating flap § picture 7 or flap keep in opened position § picture 8).

The top stop piece ref. S must absolutely be put back in place. The top access door must be closed and tightened according to advice torque (20 Nm) and the side protected cover of the mechanism has to be in place before restarting.



The device may not be put back in service if the top stop piece ref. S is not in place.

13.4. Procedure in case of an explosion :

After an explosion, the BADA-VEX mechanism can be damaged, in case of the shock violence (welding crack, flap surface distortion...). For this reason, we recommend replacing the entire BADA-VEX with a new one.

14. Dismantling and recycling

When dismantling a unit, be sure to keep in mind the following important information :

- As the unit is dismantled, set aside all still functioning parts to re-use them on another unit.
- You should always separate the different materials depending on their type: iron, rubber, oils, greases, etc.
- Recyclable parts must be disposed of in the appropriate containers or brought to a local recycling company.
-

The rubbish must be collected in special containers with appropriate labels and disposed of in compliance with the national laws and/or local legislations in force.

CAUTION !

It is strictly forbidden to dispose of toxic wastes in municipal sewerage and drain systems. This concerns all oils, greases, and other toxic materials in liquid or solid form.

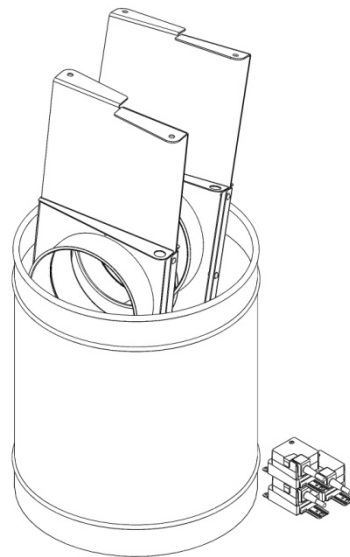

15. Maintenance log

date	description



Contacts

Formula Air The Netherlands

Head Office / Production / Sales

Bossheweg 36
5741 SX Beek en Donk,
The Netherlands
+31 492 45 15 45
info-nl@formula-air.com

Formula Air Belgium

Logistics / Sales

Rue des Dizeaux 4
1360 Perwez
Belgium
+32 81 23 45 71
info-be@formula-air.com

Formula Air Baltic

Production / Sales

P. Motiekaičio g. 3
LT-77104 Šiauliai
Lithuania
+370 41 54 04 82
info-lt@formula-air.com

Formula Air France – West

Sales

6, avenue des Lions
44800 Saint-Herblain
France
+33 9 72 15 29 38
contact-ouest@formula-air.com

Formula Air France – North

Sales

Zac de la Carrière Dorée
BP 105, 59310 Orchies
France
+33 9 72 15 29 38
contact-fr@formula-air.com

Formula Air France – East

Sales

2, rue Armand Bloch
25200 Montbéliard
France
+33 9 72 15 29 38
contact-est@formula-air.com

Formula Air France – South

Sales

Chemin de Peyrecave
09600 Regat
France
+33 9 72 15 29 38
contact-sud@formula-air.com

Formula Air Germany

Sales

Dr.-Oetker Straße 10
54516 Wittlich
Germany
+49 6571 269860
info-de@formula-air.com

Formula Air Vietnam

Production / Sales

#33, Lot 2, Den Lu 1
Hoang Mai District, Hanoi
Vietnam
+84 (24) 38 62 68 01
info@vinaduct.com

Formula Air Nordic

Sales

Stortorget 17
211 22 Malmö
Sweden
+46 40 654 06 10
info-scan@formula-air.com

Formula Air Export

Sales

Rue des Dizeaux 4
1360 Perwez
Belgium
+32 81 23 45 71
info-be@formula-air.com